

LED DISK LIGHT

QUESTIONS OR CONCERNS CONTACT CANARM AT:
 1-800-265-1833 (English) / 1-800-567-2513 (French)
 Monday through Friday 8:00 AM to 5:00 PM E.S.T.

"INSTRUCTIONS PERTAINING TO RISK OF FIRE OR INJURY TO PERSONS"
 "READ ALL INSTRUCTIONS"
"IMPORTANT SAFETY INSTRUCTIONS"
"SAVE THESE INSTRUCTIONS"

TOOLS AND MATERIALS REQUIRED:

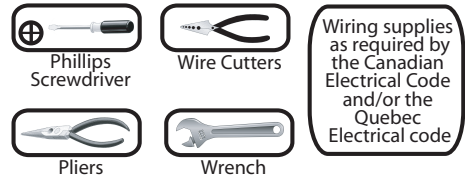

SAFETY PRECAUTIONS:

1. TURN OFF ELECTRICAL POWER BEFORE STARTING INSTALLATION OF LIGHT FIXTURE.
2. THIS PRODUCT MUST BE INSTALLED IN ACCORDANCE WITH THE APPLICABLE INSTALLATION CODE BY A PERSON FAMILIAR WITH THE CONSTRUCTION AND OPERATION OF THE PRODUCT AND THE HAZARDS INVOLVED.
3. CAUTION – RISK OF FIRE. CONSULT A QUALIFIED ELECTRICIAN TO ENSURE CORRECT BRANCH CIRCUIT CONDUCTOR.

PART	DESCRIPTION	QTY
A	LED disk light	1
B	Mounting bracket (use with option #2)	1
C	Self Tapping Screw (use with option #2)	2
D	Wire nut	1
E	E26 lamp holder (use with option #2)	1
F	Quick connector (use with option #2)	1
G	Mounting screw	2
H	Adaptor plate screw	2
I	Adaptor plate	2

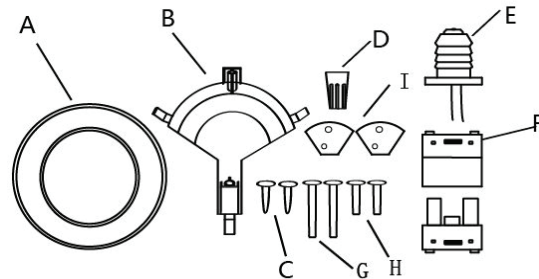

THIS LED light is suitable to be dimmed by LUTRON # CTCL-153PD

OPTION #1: FLUSH MOUNT

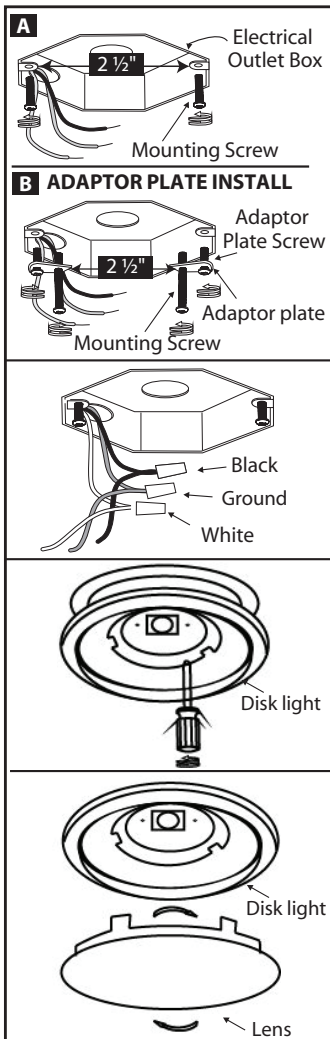

1. Prior to installation you will need to determine if the electrical box requires the adaptor plate. If the distance between the mounting screws in your electrical outlet box is greater than 2 1/2" you will need to use the adaptor plate. Securely tighten adaptor plate, with adaptor plate screws. Do not drive mounting screws completely to the end of the junction box.
2. Connect supply wires to wires on fixture with wire nuts or push wires into Quick Connector. Connect white to white, black to black, and copper wire to copper wire as grounding connection.
3. With the lens off of fixture, attach disk light to mounting screws, turn fixture counter-clockwise to lock. Tighten screws to firmly hold the fixture in place.
4. Complete the installation by twisting the lens on the disk light.

OPTION #2: RETROFIT A RECESSED CAN

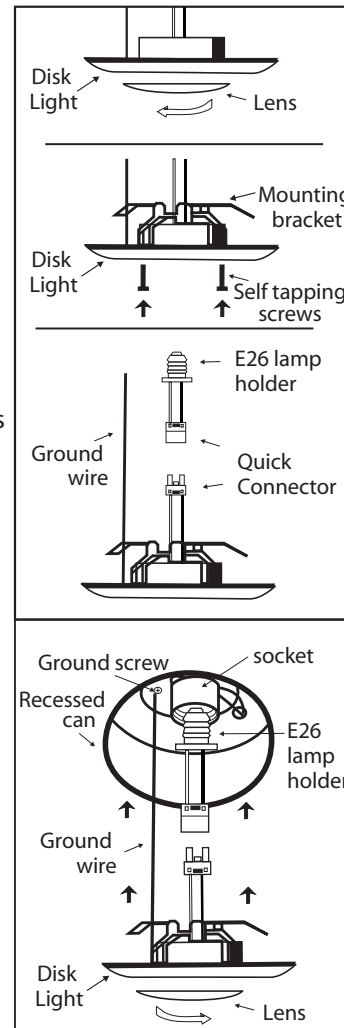

1. Prepare fixture for recessed installation.
 - Remove lens by twisting counter-clockwise
 - Attached mounting bracket and secure with self tapping screws
 - Insert wires into Quick Connector. Black to black and white to white.
2. Attach ground wire to ground screw in recessed can.
 - Turn E26 lamp holder into socket base.
 - Connect Quick Connectors
 - Tuck all wires into recessed can. Push disk light into can.
 - Twist lens onto disk light.