

WARNINGS



RISK OF FIRE, ELECTRICAL SHOCK, CUTS OR OTHER CASUALTY HAZARDS

Installation and maintenance of this product must be performed by a qualified electrician. This product must be installed in accordance with the applicable installation code by a person familiar with the construction and operation of the product and hazards involved.

RISK OF FIRE AND ELECTRIC SHOCK

Make certain power is OFF before starting installation or attempting any maintenance. Disconnect power at fuse or circuit breaker.

RISK OF FIRE

Refer to product label for specific minimum supply conductor requirements.

RISK OF BURN

Disconnect power and allow fixture to cool before handling or servicing.

RISK OF PERSONAL INJURY

Fixture may become damaged and/or unstable if not installed properly.

DISCLAIMER OF LIABILITY: CSC LED assumes no liability for damages or losses of any kind that may arise from the improper, careless, or negligent installation, handling or use of this product.

NOTICE: Green ground wire provided in proper location. Do not relocate.

SAFETY: This fixture must be wired in accordance with the National Electrical Code and applicable local codes and ordinances. Proper grounding is required to insure personal safety. Carefully observe grounding procedure under installation section.

APPLICATIONS: This lighting fixture is designed for outdoor lighting services, and should not be used in area of limited ventilation or inside high ambient temperature enclosures. It must be stored in a dry location prior to installation. Do not expose lighting fixture to rain, dust or other environmental conditions prior to installation and insertion of photo control or shorting cap (if so equipped). Best results will be obtained if installed and maintained according to the following recommendations.

ATTENTION RECEIVING DEPARTMENT: Note actual fixture description of any shortage or noticeable damage on delivery receipt. File claim for common carrier (LTL) directly with carrier. Claims for concealed damage must be filed within 15 days of delivery. All damaged material, complete with original packing must be retained.

INSTALLATION INSTRUCTIONS

1. Turn off the power.
2. Loosen 4 screws. (Fig. 1)
3. Remove the ½" end cap. (Fig. 2)
4. Peel off the yellow sticker and paste the foam gasket on the round area of the bottom plate. (Fig. 3)
5. Affix the bottom plate on the pre-drilled wall or junction box. (Fig. 4)
6. Connect the luminaire to supply wires. (Fig. 5)
7. Secure luminaire with the 4 screws. (Fig. 6)
8. Ensure all wiring and fasteners are secured and then turn power on.

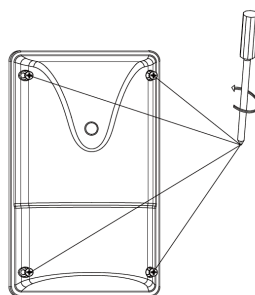

Fig. 1

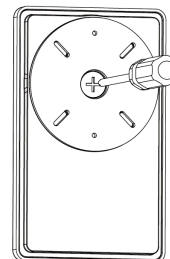

Fig. 2

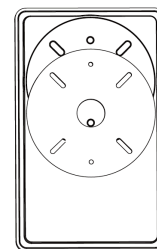

Fig. 3

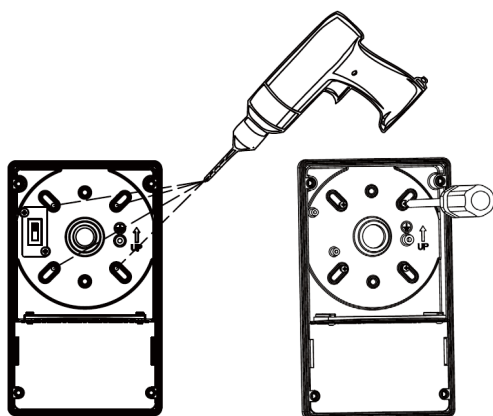

Fig. 4

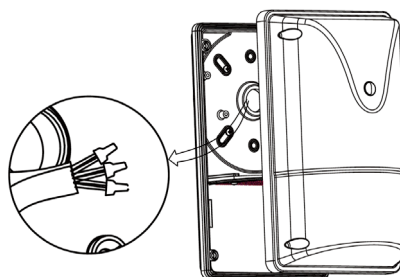

Fig. 5

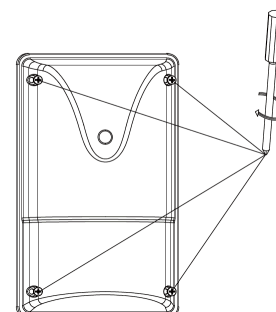

Fig. 6

WATTAGE AND CCT SELECTION

1. Turn off the power.
2. Loosen 4 screws. (Fig. 7)
3. Select your desired power and colour temperature settings with the switch and secure the luminaire with the 4 screws (Fig. 8)
4. Ensure all wiring and fasteners are secured and then turn power on.

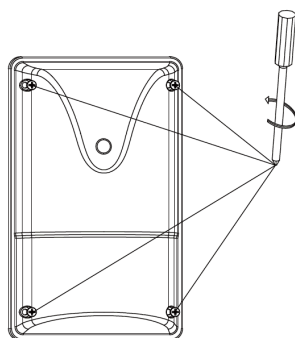
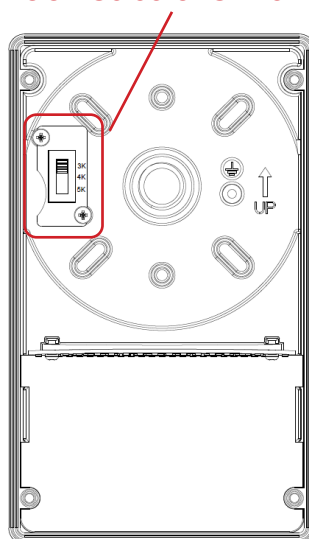

Fig. 7

CCT Selector Switch



Power Selector Switch

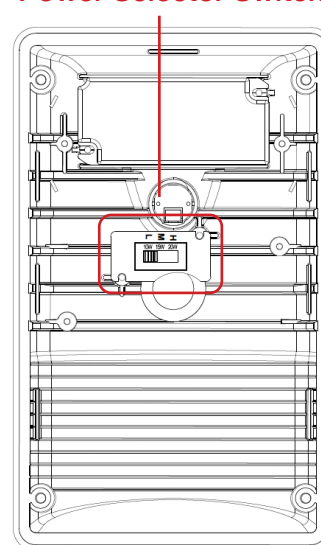

Fig. 8

WIRING DIAGRAM

