

Assembly Instruction Sheet #IS-1027C23-6

For Style 1027C23-6

Tools Required: Flathead screwdriver, Phillips screwdriver, pliers, wire cutters, wire strippers, electrical tape, safety glasses.

Light Source: (6) E12 Candelabra Base Bulbs 60W Maximum (Not include).

Estimated Assembly Time: 30-40 minutes

Preparation: Identify and inspect all parts before beginning installation. Check package content list and diagrams below to be sure all parts are present. If any parts are missing or damaged, do not attempt to assemble, install, or operate the fixture. Contact customer service for replacement parts.

⚠ Warnings and Cautions

Turn off electricity at circuit breaker or main fuse box before installation. Consult a licensed electrician if in doubt.

These instructions are provided for your safety. It is very important you read them completely before installing the fixture.

We strongly recommend that a licensed, professional electrician perform the installation.

Disconnect fixture from power source before replacing bulbs. Make sure bulbs are given sufficient time to cool before removal.

Package Contents

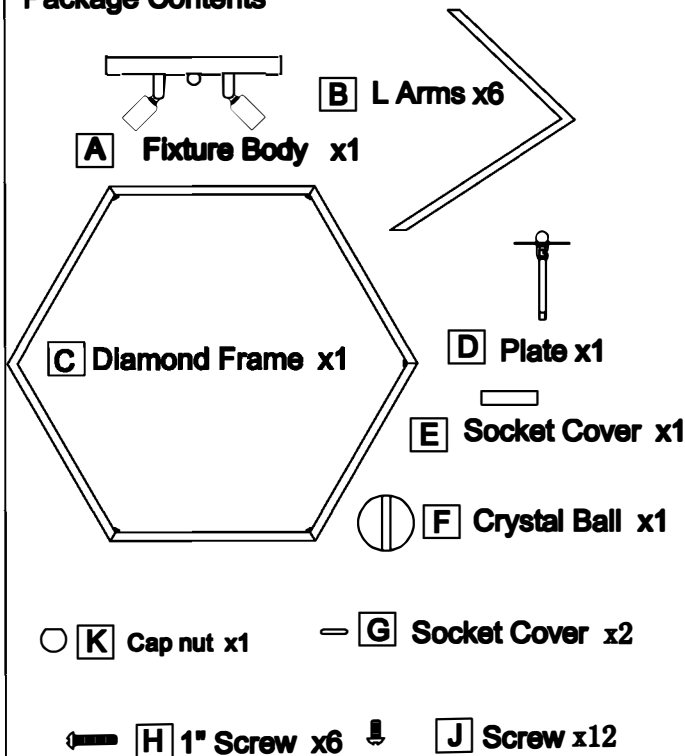

STEP 1 - Install L Arms and Diamond Frame to Fixture Body.

A. Connect the L Arms (B), Fixture Body (A) and Plate (D) with Screw (J) but please don't tighten them.

B. Put the Diamond Frame (C) into the six L Arms (B), then adjust the arms to six corner place. Line up the holes on the Diamond Frame (C) and the holes on the L Arms. Use the 1" Screw (H) to fix them together, tighten the Screw (J). Use the cap to stem the holes on the arms.

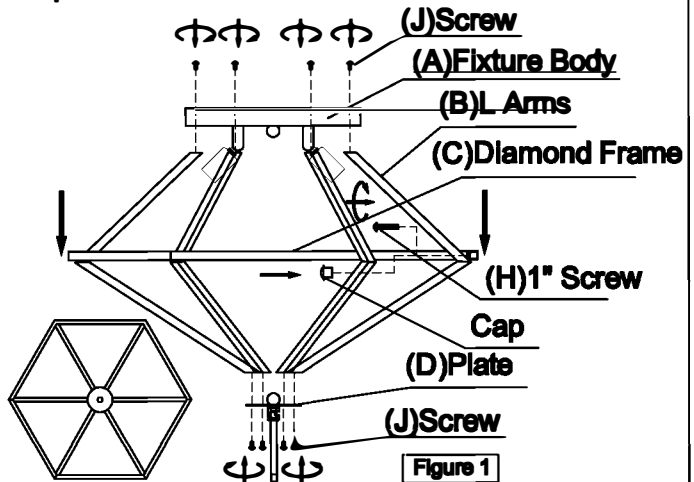

STEP 2 - Attach Mounting Screws, Lock Washers and Hex Nuts to Mounting bracket.

A. Line up a set of holes on the Mounting bracket (EE) and Holes on the ceiling canopy.

Thread Mounting Screws (DD)

into the holes on the Mounting bracket (EE).

Pass Lock Washers and thread Hex

Nuts onto the Mounting

Screws (DD).

Hand tighten until snug.

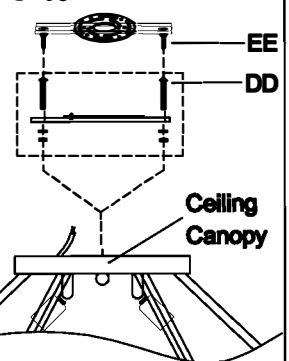

Hardware Contents

PART	DESCRIPTION	QUANTITY
AA	Cap nut	2pcs
BB	Wire nut	3pcs
CC	Outlet Box Screw	2pcs
DD	Mounting Screw	2pcs
EE	Mounting bracket	1pcs

