

LED PHB HIGH BAY III

CUSTOMER PROJECT

Project: _____
 Type: _____
 Cat. No.: _____
 Qty: _____
 Date: _____
 EEL Rep: _____



solutions closer to nature

Telephone: 905 415 8878 Fax Number: 905 415 8872 Toll Free Telephone: 855 415 8878 Toll Free Fax: 855 415 8872

PRODUCT DESCRIPTION

The High Performance LED High-Bay III is the lighting solution for a wide variety of applications and mounting heights. It has a newly improved, modern sleek design to create a lighter, more refined fixture. Precision-designed optics, multiple distributions and a choice of lumen outputs makes the LED High-Bay the ideal solution for industrial, commercial and recreational applications.

SPECIFICATION FEATURES

Construction

- Cold forged steel white rims
- Removable cover for integrated sensor
- Suitable for Damp Locations
- Working Temperature: -20°C to 40°C
- 10 ft cord and "V" hooks and chain are included

Electrical

- Electronic Drivers are available in 120-277 or 120-347 Volt
- 0-10V Dimming
- 2KV Surge Protection for 120-277V
- 4KV Surge Protection for 100-347V
- LED's available in 5000K & 4000K
- CRI > 80
- L70 > 240,000h
- L₃₆₀₀₀ = 94.9%

Beam Angle

120 degrees standard

Shielding

Polystyrene (PS) Lens provides ideal lighting coverage and minimal glare

Compliance

cULus, DLC

Warranty

5 years



HIGH PERFORMANCE LED HIGH BAY III

Mounting

- Pendant Mount
- Suspension Mount

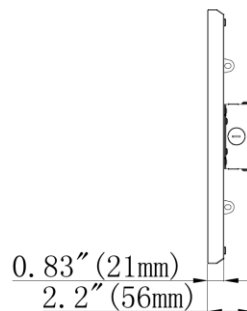
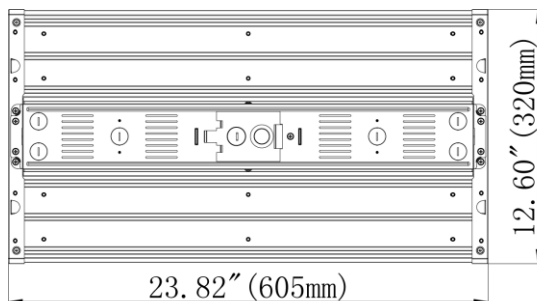

PHB-III-2-110W
 Dimensions
 mm | 605(L) x 320(W) x 56(D)
 inch | 23.8(L) x 12.6(W) x 2.2(D)

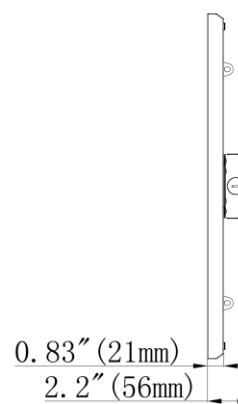
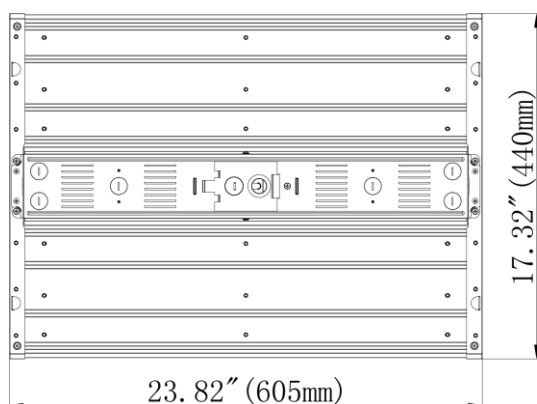

PHB-III-2-165W/ PHB-III-2-220W
 Dimensions
 mm | 605(L) x 440(W) x 56(D)
 inch | 23.8(L) x 17.3(W) x 2.2(D)

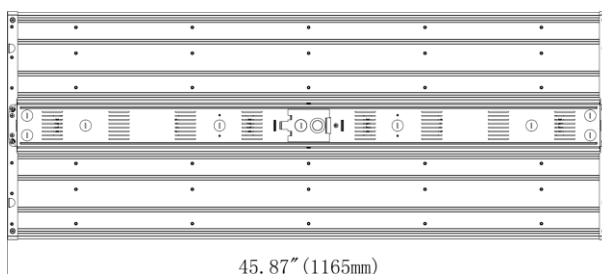





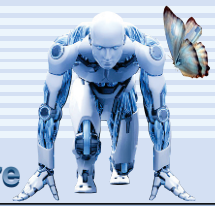











PHB-III-4-320W
 Dimensions
 mm | 1165(L) x 440(W) x 56(D)
 inch | 45.8(L) x 17.3(W) x 2.2(D)





ORDERING CODE, ENERGY AND PERFORMANCE DATA

	Model No.	Delivered Lumens (lm)	Input Watts (W)	Voltage (V)	Colour Temp. (K)	Efficacy (lm/W)	Certification	Type
	PHB-III-4-320W40K-MV PHB-III-4-320W50K-MV	42314 43304	331 331	120-347 120-347	4000K 5000K	128 131		Standard
	PHB-III-4-320W40K PHB-III-4-320W50K	45511 46415	345 346	120-277 120-277	4000K 5000K	132 134		Standard
	PHB-III-2-220W40K-MV PHB-III-2-220W50K-MV	29545 30236	219 219	120-347 120-347	4000K 5000K	135 138		Standard
	PHB-III-2-220W40K PHB-III-2-220W50K	27725 28279	212 212	120-277 120-277	4000K 5000K	131 133		Standard
	PHB-III-2-165W40K-MV PHB-III-2-165W50K-MV	22747 23280	163 163	120-347 120-347	4000K 5000K	139 143		Standard
	PHB-III-2-165W40K PHB-III-2-165W50K	19222 19629	147 147	120-277 120-277	4000K 5000K	131 133		Standard
	PHB-III-2-110W40K-MV PHB-III-2-110W50K-MV	14212 14545	109 109	120-347 120-347	4000K 5000K	130 133		Standard
	PHB-III-2-110W40K PHB-III-2-110W50K	13646 13940	106 106	120-277 120-277	4000K 5000K	128 131		Standard

NOTE:

- Lumens are estimated.
- Lumens may vary based on lens option.
- DLC qualified may not apply to all versions within a model. Please check the DLC Qualified Products List at www.designlights.org to confirm which versions are qualified.

OPTIONAL ACCESSORIES

PHB-III-2WGA | Wire Guard for 2ft 110W only
 PHB-III-2WGB | Wire Guard for 2ft 165W & 220W only
 PHB-III-4WG | Wire Guard for 4ft only
 PHB-III-PH | Pendant Hanger

CONTROLS (OPTIONAL)

MC601V | Microwave Motion Sensor (For 120-277V only)
 YM2502 | High Bay Occupancy Sensor 120-277V / 347V



