

CDR : Commercial Downlight Retrofit



project name	type
catalog number	
comments	voltage
approved by	date

25/
35/50
watts

2200/
4200
watts

up to
70
lpw

54,000
hours

Features

- Fits existing architectural and commercial housing
- Lasts 4 times longer than CFL
- 120-277V circuit with 0-10V dimming driver (standard)
- Easy installation - Quick connector and pre-wired conduit
- Comfortable diffused light
- 10-100% dimming range
- 5 year warranty

Performance

- Reported L70 (hours) >54,000
- Operating temperature: -40°C (-40°F) to 40°C (104°F)
- Suitable for use in dry or damp locations
- 3000K, 3500K, 4000K CCT
- CRI: >80
- Input voltage: 120~277VAC
- Power Factor: 0.9
- THD: <20%

Applications

- Hotel Lobby
- Shopping Center
- Supermarket
- Recreation Center
- Public Arreas
- Corridors
- Offices
- Schools
- Hospitality
- Retail

Ordering Information

Order Code	Item #	Size	Lm	W	CCT	CRI	MOL	Life/Hrs	Notes	Replaces Incan.	ENERGY STAR
09234	CDR-3C-830K-U	6"	2,200	25W	3000K	80+	5.39"	54,000	6.1"-6.9" Aperture	(2) 18W CFL	★
09235	CDR-3C-835K-U	6"	2,200	25W	3500K	80+	5.39"	54,000	6.1"-6.9" Aperture	(2) 18W CFL	★
09236	CDR-3C-840K-U	6"	2,200	25W	4000K	80+	5.39"	54,000	6.1"-6.9" Aperture	(2) 18W CFL	★
09237	CDR-4C-830K-U	8"	3,000	35W	3000K	80+	5.9"	54,000	7.8"-8.6" Aperture	(2) 26W CFL	★
09238	CDR-4C-835K-U	8"	3,000	35W	3500K	80+	5.9"	54,000	7.8"-8.6" Aperture	(2) 26W CFL	★
09239	CDR-4C-840K-U	8"	3,000	35W	4000K	80+	5.9"	54,000	7.8"-8.6" Aperture	(2) 26W CFL	★
09240	CDR-5C-830K-U	10"	4,200	50W	3000K	80+	6.5"	54,000	9.4"-10.2" Aperture	(2) 42W CFL	★
09241	CDR-5C-835K-U	10"	4,200	50W	3500K	80+	6.5"	54,000	9.4"-10.2" Aperture	(2) 42W CFL	★
09242	CDR-5C-840K-U	10"	4,200	50W	4000K	80+	6.5"	54,000	9.4"-10.2" Aperture	(2) 42W CFL	★

★ ENERGY STAR® Approved



RoHS
Compliant



selection. solutions. simplicity. eiko.com

CDR : Commercial Downlight Retrofit

Dimensions

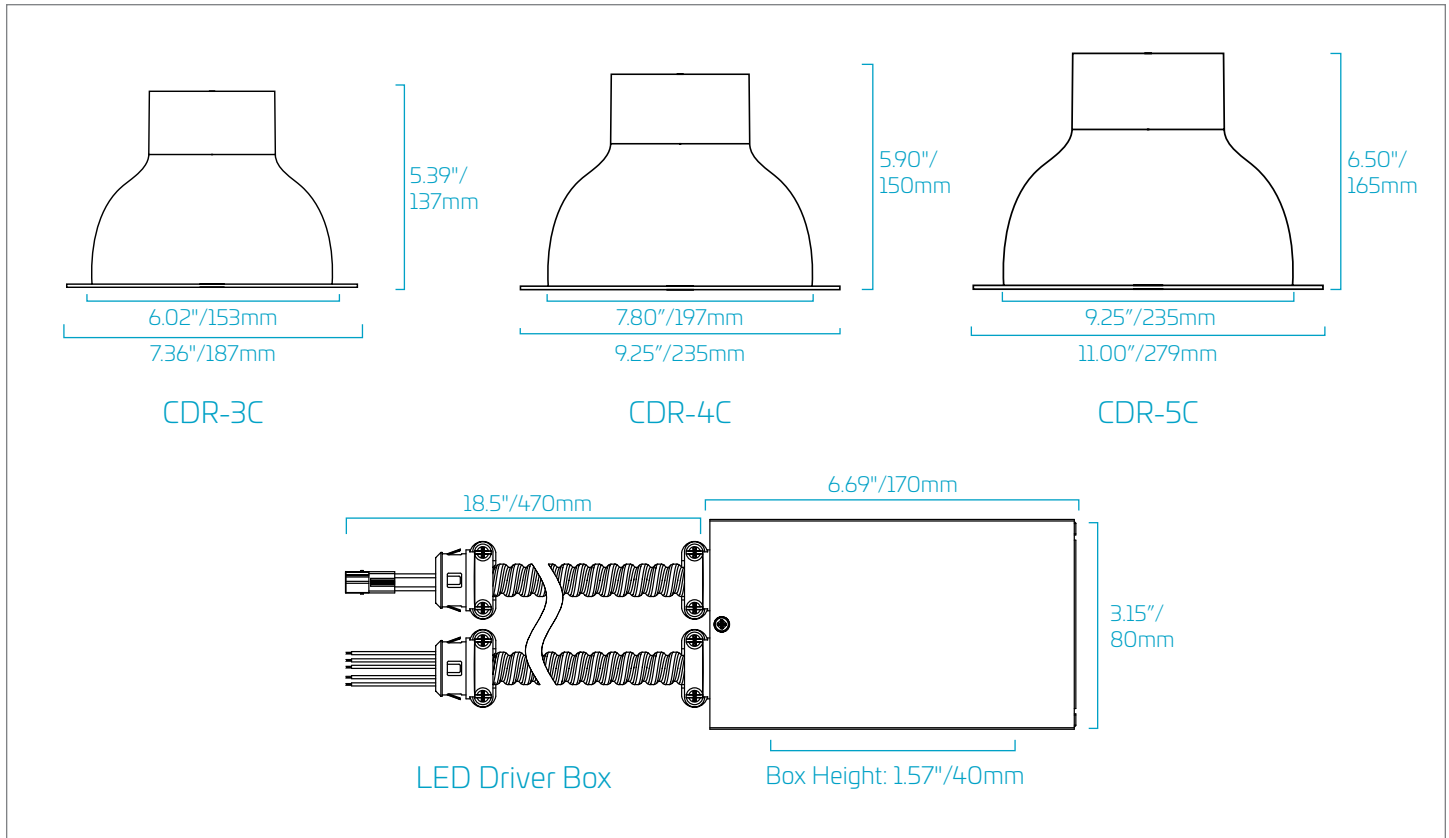

Accessories Included

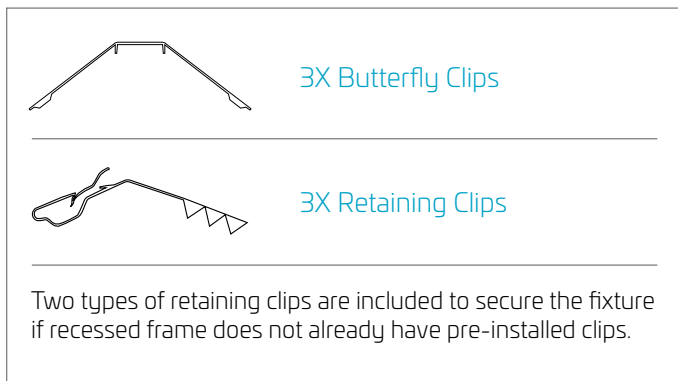

Accessories (Sold Separately)

Order Code	Litespan Part #	Description
09849	FHSCP-UNV-5WL	5W Emergency Battery Backup
09851	FHSCP-UNV-7.8WL	7.8W Emergency Battery Backup
09850	FHSCP-UNV-10.7WL	10.7W Emergency Battery Backup
09852	FHSCP-UNV-13.7WL	13.7W Emergency Battery Backup
09854	FHSCP-UNV-17WL	17W Emergency Battery Backup

watch > like > follow

