

LED Bypass/Line Voltage T8 Tube Lights : 8'



43
watts

5,500
lumens

4000/
5000K
CCT

80+
CRI

Features

- Solid state replacement for high output 8' T8 and T12 fluorescent lamps
- Direct replacement of single-pin LED slimline with HO-equivalent lumen output
- Double-ended single contact base – same as T8 and T12 lamps
- Simple installation; bypass ballast, connect line voltage to single-pin sockets
- Frosted lens for uniform diffuse appearance
- No ballast or external driver required
- High Output: 5,500 lumens; 127lpw
- Lifetime exceeds 50,000 hrs
- Choice of 4000K or 5000K CCT
- Instant-On with no warm up like fluorescents
- NSF listed for commercial foodservice equipment
- RoHS compliant mercury-free for safer operation



Performance

- 8' 43W LED replaces 59W T8 or 60/75W T12 fluorescent lamps
- Long life: 50,000 hours
- 80+ CRI
- Integral 120~277V drivers provide easy installation
- Wide ambient temperature range from -20°C (-4°F) to 45°C (113°F)
- <20% Total Harmonic Distortion
- Contains no mercury or lead; classified as non-hazardous waste
- Existing fixture maintains original UL compliance per UL1598C listing
- Damp location rated
- Does not operate on emergency backup

Applications

- Commercial
- Conference rooms
- Hospitality
- Education
- Healthcare
- Retail
- Residential



NOTE: \$1500 minimum total order required for paid freight when purchasing any 8' T8 products. Product ships on 8' pallet in case quantities only.

LED Bypass/Line Voltage T8 Tube Lights : 8'

Dimensions

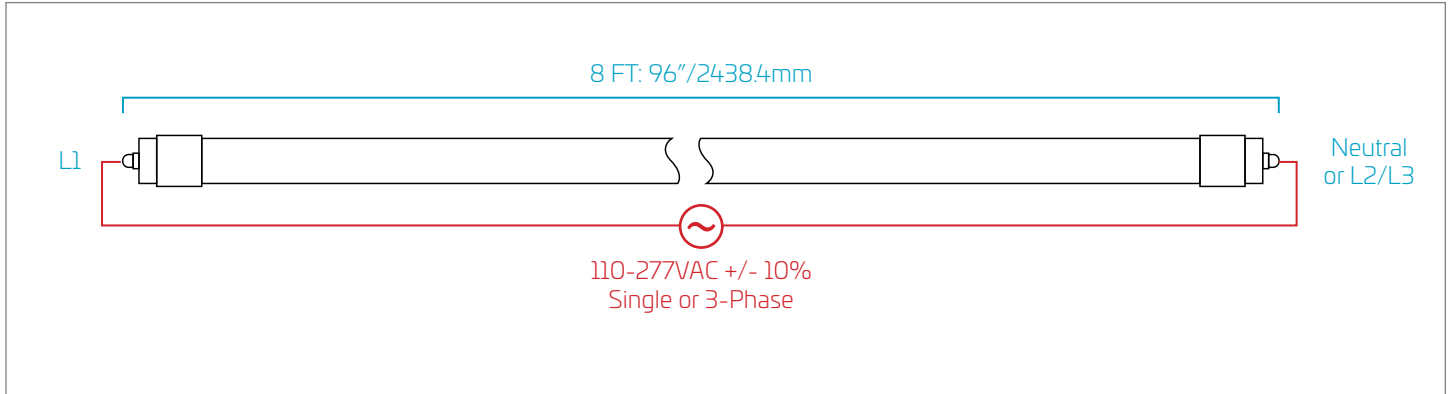

Ordering Information

Order Code	Item #	Length	W	Lm	CCT	CRI	Appearance	Envelope	Life/Hrs	DLC
09567	LED43WT8/96/840-DBL-G7D	8'	43W	5,500	4000K	80+	Frosted	Glass	50K	✓
09568	LED43WT8/96/850-DBL-G7D	8'	43W	5,500	5000K	80+	Frosted	Glass	50K	✓

NOTE: Use order code when ordering.

✓ DesignLights Consortium® Qualified



NSF offers the most accepted and trusted certification and verification programs for commercial foodservice equipment, specified by health departments, restaurant buyers and specifiers worldwide. NSF means market access – products with the NSF mark receive guaranteed regulatory acceptance in North America and improved acceptance worldwide. Verification programs, such as HACCP Compliance Verification - EU, demonstrate hygienic quality, independently verified by a trusted source.

watch > like > follow

