



KT-LED82P-0-8XX-D

2-PIN LED LAMP

DESCRIPTION

8W 2-Pin LED Omni-Directional Lamp | ≥ 80 CRI | Line-Voltage Compatible



LAMP TYPE: Compact LED
BULB TYPE: 2-Pin LED
BASE TYPE: G24d, G24q, GX24q
WATTAGE: 8W
COLOR TEMPERATURE: 2700–5000K
CFL EQUIVALENT: 13W, 18W, and 26W
COLOR RENDERING INDEX (CRI): ≥ 80
WARRANTY: 5 Years



PRODUCT FEATURES

- Replacement for 13W/18W/26W G24d, G24q & GX24q CFL lamps
- Ideal for wall-mounted and ceiling applications
- 50,000+ hour lifetime
- Power factor: >0.9
- Environmentally friendly: No mercury used
- Die-cast aluminum heat sink
- Instant startup
- Suitable for dry and damp locations
- Frosted lens eliminates pixelation
- Approximately 50% more energy efficient than traditional CFL lamps
- Ideal for totally enclosed fixtures
- Operating temperature: $-20^{\circ}\text{C}/-4^{\circ}\text{F}$ to $40^{\circ}\text{C}/105^{\circ}\text{F}$
- Non-dimmable
- 260° beam angle
- UL damp listed

OPERATING SPECIFICATIONS

ELECTRICAL CHARACTERISTICS

Input Voltage	Lamp Wattage	Power Factor
120–277Vac	8W	>0.9

PHOTOMETRIC CHARACTERISTICS

Color Temperature (CCT)	2700K	3000K	3500K	4000K	5000K
Luminous Flux	800 lm	800 lm	800 lm	800 lm	800 lm
Color Rendering Index (CRI)	≥ 80	≥ 80	≥ 80	≥ 80	≥ 80
Efficacy	100 lm/W	100 lm/W	100 lm/W	100 lm/W	100 lm/W
Beam Angle	260°	260°	260°	260°	260°

RATED LIFE

L70 (Hours)	50,000
-------------	--------

SPECTRAL DISTRIBUTION

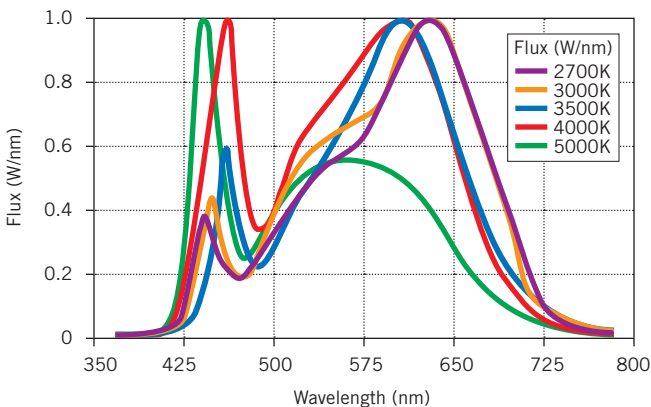



KT-LED82P-O-8XX-D

2-PIN LED LAMP

PHYSICAL CHARACTERISTICS

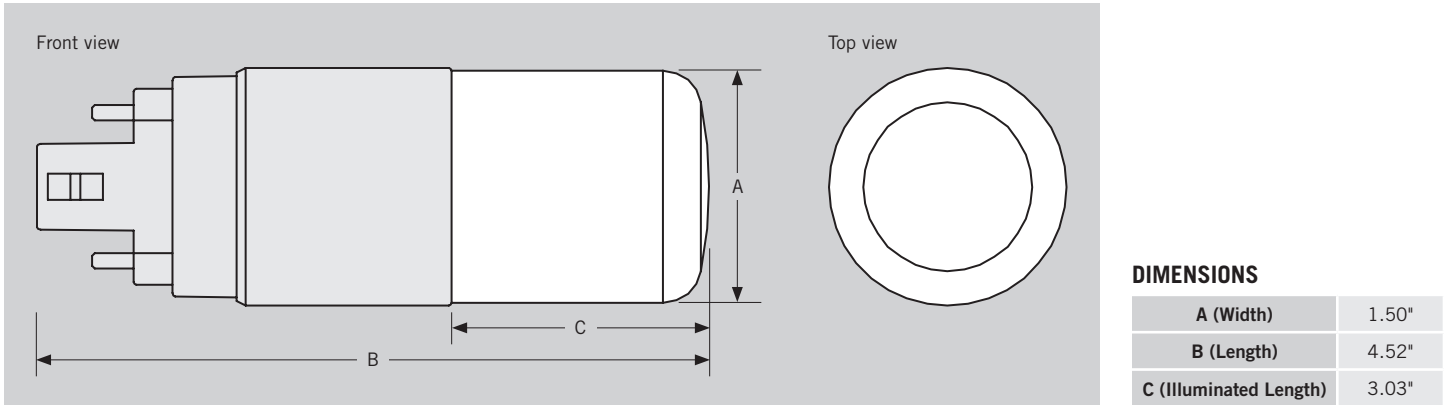

WIRING INSTRUCTIONS

STEP 1

Disconnect power. Remove can cover (if applicable) and remove existing lamps from fixture.

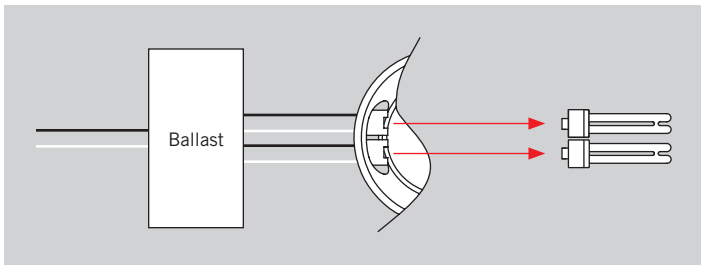

STEP 2

Cut and remove all wires connected to ballast.

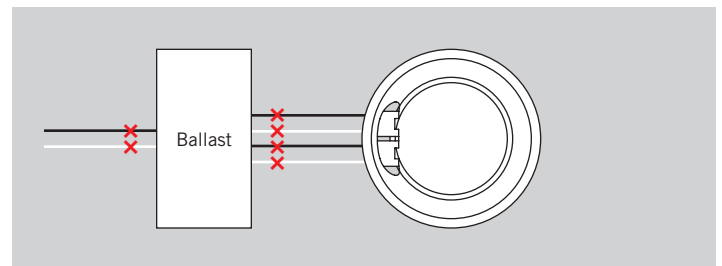

STEP 3

Connect AC input wires to lamp sockets.

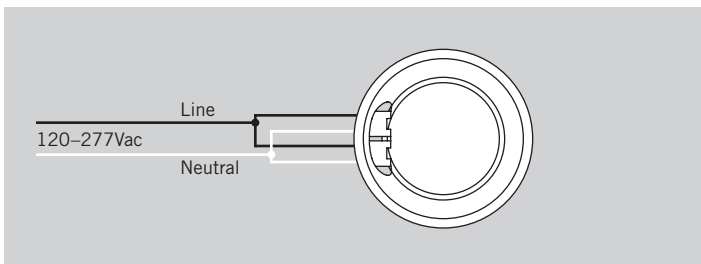

STEP 4

Install replacement G24d LED lamps into sockets. Replace can cover, ensuring that all connecting wires are covered by metal housing. Reconnect power.

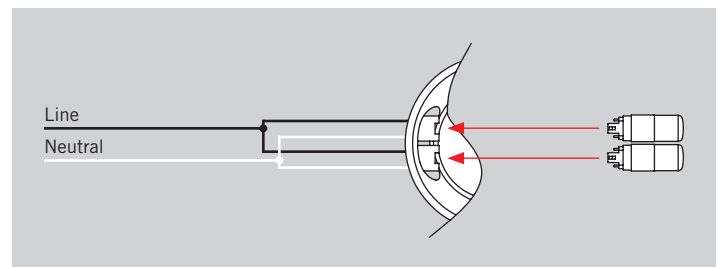



KT-LED82P-O-8XX-D

2-PIN LED LAMP

ORDERING INFORMATION

ORDER CODE	PACK QTY.	EASY CODE	UPC
KT-LED82P-O-827-D	50	GJI-26	843654126890
KT-LED82P-O-830-D	50	EMQ-20	843654126906
KT-LED82P-O-835-D	50	NOP-94	843654126913
KT-LED82P-O-840-D	50	KZU-89	843654126920
KT-LED82P-O-850-D	50	CRO-51	843654126937

CATALOG NUMBER BREAKDOWN

KT-LED82P-O-8XX-D

1 2 3 4 5 6 7 8

- 1 Keystone Technologies
- 2 LED Lamp
- 3 Wattage
- 4 Lamp Type
- 5 Omni-Directional Orientation
- 6 800 Series
- 7 Color Temperature
- 8 Direct Drive Series