

Type
Project
Catalog No.
Lamp/Wattage

**NRS17-301**

**Nepro Wall Wash**

Lamp: (1) 150W 120V T type Halogen lamp (150W included)

**PRODUCT DESCRIPTION**

Line voltage linear halogen wall wash luminaire.

**SPECIFICATION**

**HOUSING**

0.07" die-cast aluminum housing. Lamp Containment Barrier - Heat resistant glass, frosted lamp shield, min 0.12" thick, overall 5-3/8" long by 1-1/8" wide; mechanically secured to lampholder by metal clips.

**ELECTRICAL**

**WIRING**

Size: 18 Gauge AWG 200°C, 300V

**SOCKET**

R7S base rated for 250V, 150W max.; secured to enclosure by corrosion protected or resistant metal brackets.

**UNIVERSAL CONNECTOR**

Construction: 0.07" die cast aluminum shell  
 Contacts: Copper for positive and neutral Copper contact spring on top to provide solid contact with ground conductor located on top of rail.

**FINISHES**

Brushed Nickel and Bronze are available.

**LABELS AND LISTINGS**

cULus Listed for dry location only.

**DIMENSIONS**

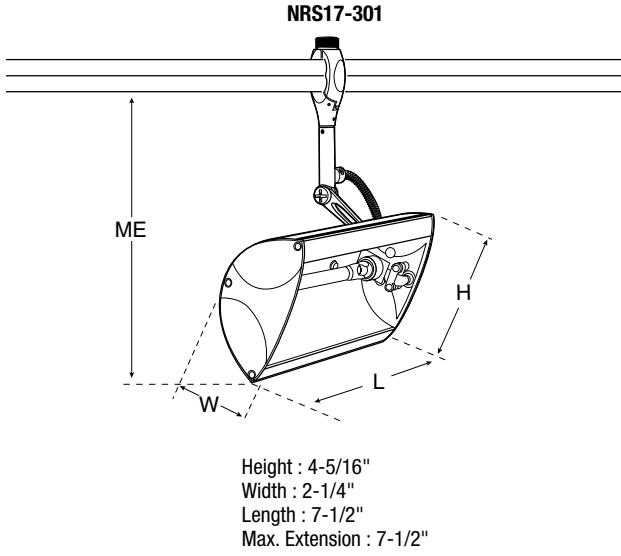

**Nepro Wall Wash**

Catalog No.	Finish
<b>NRS17-301</b>	<b>BN</b> = Brushed Nickle <b>BZ</b> = Bronze <b>S</b> = Silver

Create a complete item number: Example: **NRS17-301BN**