

Smart Controller

MODEL ODDMF-ST



HIGHLIGHTS

6 speed smart controller with thermal probe; compatible with mixed flow inline ODDMF fans/silencers

Comes with thermal probe, which is for:

- Monitoring environmental temperature
- Accurate ventilation and energy saving
- Mode selection of Manual, Auto and Alert
- Supporting control of up to 4 EC fans simultaneously

COMPATIBLE FANS



4" Mixed flow inline fan
ODDMF-4-160



5"/6"/8"/10"/12" Mixed flow inline fans
ODDMF-5-166
ODDMF-6-350
ODDMF-8-710
ODDMF-10-1065
ODDMF-12-1750



6"/8"/10"/12" Mixed flow Silencers
ODDMF-6-350-Q
ODDMF-8-710-Q
ODDMF-10-1065-Q
ODDMF-12-1750-Q

DIMENSIONS

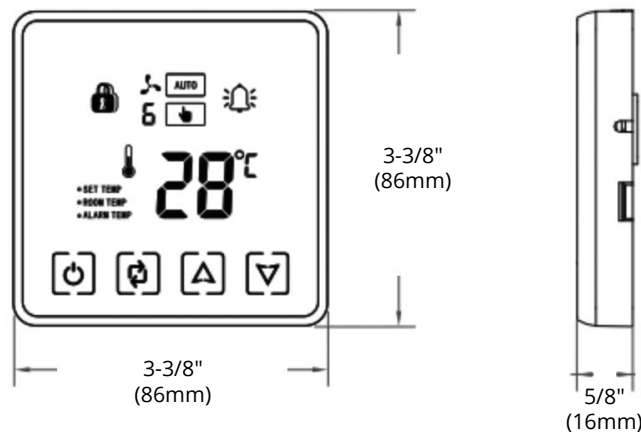

Reference	QTY.	Remarks	Project:
			Location:
			Architect:
			Engineer:
			Contractor:
			Submitted by:
			Date:

ORTECH reserves the right to modify at any time, without notice, any or all of our product's features, designs, components and specifications to meet market changes.