



CW2 SERIES COMMERCIAL WRAP AROUND

INSTALLATION INSTRUCTIONS



For use with:

CW2-404-1

WHAT'S IN THE BOX

- LED Fixture
- Small Pin Cross Machine Screws x 2 (AA)
- Wire Nuts x 3 (BB)
- Pointed Pin Cross Wood Screws x 4 (CC)
- Wall Anchors x 4 (DD)

WHAT YOU'LL NEED

- Screwdriver / Drill
- Wire Cutters
- Wiring supplies as specified by Electric Code

WARNING

- Read all safety precautions and installation instructions carefully before installing
- Do not handle any energized fixture or attempt to energize any fixture with wet hands or while standing on a wet or damp surface or in water
- Ensure that the fixture is mounted onto a structurally sound surface that will support the fixture
- The fixture is designed for use in a 100-277VAC, 60Hz fused circuit. Do not use in a dimming circuit
- Do not install on a radiant-heating type ceiling

FAILING TO FOLLOW THESE INSTRUCTIONS MAY LEAD TO A POTENTIALLY FATAL ELECTRICAL SHOCK OR PROPERTY DAMAGE

IMPORTANT

Before assembling your fixture, please make sure that you carefully read through this instruction sheet. Ensure your fixture is installed by a qualified licensed electrician.

Note: The important safeguards and instructions that appear in this sheet are not meant to cover all possible conditions and situations that may occur. It must be understood that common sense, caution, and care are factors that cannot be built into any product. These factors must be supplied by the person(s) caring for and operating the fixture.

PREMISE LED Inc.
80-86 Carrier Drive
Toronto, ON Canada
M9W 5R1
PREMISELED.COM

FIXTURE COMPONENTS

The LED Wraparound consists of three components: the housing (A) diffuser (C), and end pieces (D).

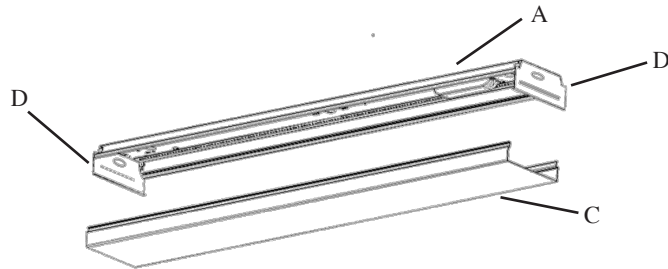

HOW TO INSTALL THE WRAPAROUND

1. Insert the two Small Pin Cross Machine Screws (AA) into the junction box. Do not tighten.
2. Remove the diffuser (C) Do this by removing the two screws attached to an end piece (D), then sliding the diffuser out.
3. Connect the ground wire from the junction box to the yellow/green ground wire of the fixture, the white wire to the white, and the black wire to the black. For each, place Wire Nuts (BB) over the connected wires and twist clockwise until tight.

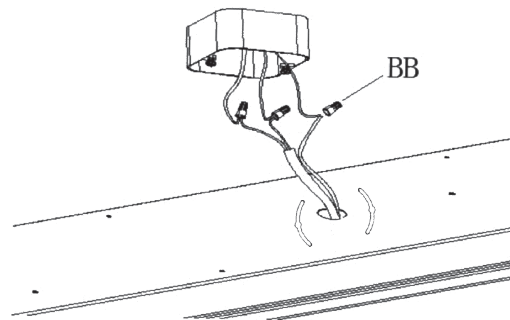
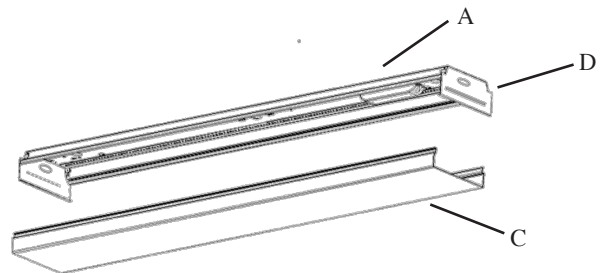
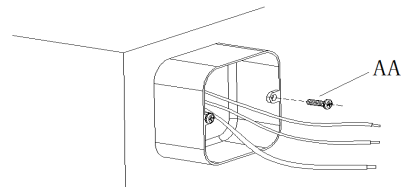

HOW TO INSTALL CONTINUED

4. Attach the fixture housing (A) to the junction box by aligning the holes on the housing with the two Small Pin Cross Machine Screws (AA) on the junction box from Step 1.
5. Turn the housing (A) clockwise to lock the fixture in place, then tighten the Small Pin Cross Machine Screws (AA) to secure.
6. With the fixture secured, insert the Pointed Pin Cross Wood Screws (CC) through the housing (A) and fasten the screws into the ceiling. Repeat for all 4 screws.
7. Reinstall the diffuser (C) by sliding the diffuser back into place. Reattach end piece (D) using their two screws.
8. Installation is now complete.

