

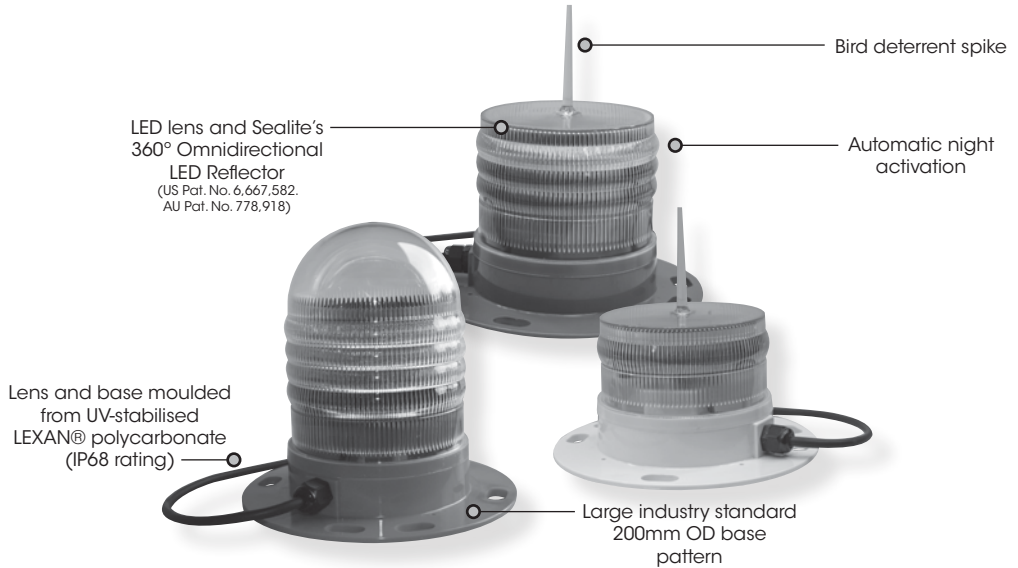

**SL-125 Series & SL-125 Complete**  
**5-9NM+ LED Marine Lantern**  
**Installation & Service Manual**

# SL-125 Series

## 5-9NM+ LED Marine Lantern



# SL-125 Complete

## 5-9NM+ Complete Marine Lantern Assembly

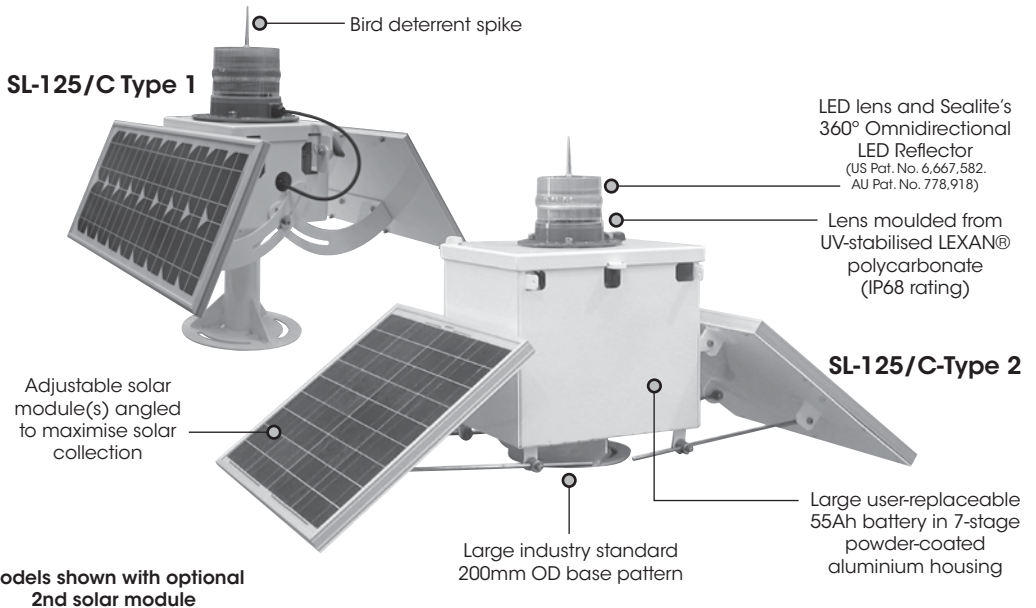

**Table of Contents**

**Introduction**.....Page 4

**Operating Principle** .....Page 4

**Technology**.....Page 4

**SL-125 & SL-125-C Models** .....Page 5

    SL-125 Series.....Page 6

    SL-125 Complete Available Configurations.....Page 8

    SL-125 Type 1 Complete.....Page 9

    SL-125 Type 2 Complete.....Page 10

**Optional Configurations** .....Page 12

**Installation**.....Page 13

**Selecting an Intensity/Power Setting**.....Page 14

**Selecting a Flash Code** .....Page 14

**RF Synchronisation (Comm-Sync) Option** .....Page 15

**GPS Synchronisation Option** .....Page 16

**Lantern Status** .....Page 17

**Flash Codes** .....Page 19

**Maintenance and Servicing**.....Page 24

**Trouble Shooting**.....Page 25

**Sealite Lantern Warranty** .....Page 26

Version No.	Description	Date	Approved
3.1	Update Manual	May 2010	A. Dixon
3.2	Logo Update	August 2010	K. Paton
4.0	Update: Quality Logo	May 2011	J. Dore
4.1	Update: Spec Tables	May 2012	J. Dore
4.2	GPS info update	July 2012	J. Dore
4.3	Spec table update	February 2015	J. Dore
4.4	Update: Contact details	February 2016	J. Dore

## Introduction

**Congratulations! By choosing to purchase a Sealite lantern you have become the owner of one of the most advanced LED marine lanterns in the world.**

Sealite Pty Ltd has been manufacturing lanterns for over 25 years, and particular care has been taken to ensure your lantern gives years of service.

As a commitment to producing the highest quality products for our customers, Sealite has been independently certified as complying with the requirements of ISO9001:2008 quality management system.

Sealite lanterns comply with requirements of the US Coast Guard in 33 CFR part 66 for Private Aids To Navigation.

By taking a few moments to browse through this booklet, you will become familiar with the versatility of your lantern, and be able to maximise its operating function.

## Operating Principle

The solar module of the lantern converts sunlight to an electrical current that is used to charge the battery (SL-125-C models only). The battery provides power to operate the lantern at night.

The flasher unit has very low current requirements. A microprocessor drives an array of ultra bright LED's through a DC/DC converter, which enables the LED's to operate within the manufacturer's specifications. The battery is protected from over-charging within the circuit to ensure maximum battery life.

In darkness, the microprocessor will initiate a program check and after approximately 1 minute begin flashing to the set code

## Technology

***Sealite is the world's fastest growing manufacturer of marine aids to navigation. We employ leading mechanical, optical, hardware & software engineers to create innovative products to service the needs of our customers worldwide, and offer the widest range of solar-powered LED lanterns in the marketplace.***

### Electronics

Sealite employs leading in-house electronic engineers in the design and development of software and related circuitry. All individual electronic components are sourced directly by Sealite procurement staff ensuring that only the highest quality components are used in our products.

### LED Technology

All marine lanterns use the latest advancements in LED (Light Emitting Diode) technology as a light source. The major advantage of LED's over traditional light sources is well established in that they typically have an operational life in excess of 100,000 hours, resulting in substantial savings to maintenance and servicing costs.

### Precision Construction

Commitment to investing in the design and construction of injection-moulded parts including optic lenses, light bases and a range of other components ensures that all Sealite products are of a consistent & superior quality.

### Optical Performance

Sealite manufactures a range of marine LED lenses moulded from multi-cavity dies. Complex shapes such as the SL70, BargeSafe™ and 16-segment multi-focus lenses are a testament to the company's superior in-house lens manufacturing capabilities and outstanding optical performance.

### Award-winning, Patented Technology

Several United States and Australian patent registrations are held on Sealite's range of innovative designs, with other regional patents pending in Canada, United Kingdom and Europe.

## SL-125 & SL-125-C Models

*The SL-125 5-9NM+ light fixture is the most advanced LED marine lantern on the market. Utilising the latest software and micro circuitry developments, the lantern boasts a huge number of features including flash-memory and the most efficient power conversion available.*

*This maintenance-free model is also available with up to 4 tiers of 36 LEDs to increase the light intensity for a range of different light colours (see Specifications table below). Each LED tier utilises the Sealite omnidirectional LED Reflector (US Pat. No. 6,667,582. AU Pat. No. 778, 918) to increase the intensity and uniformity of the horizontal output. In particular, the SL-125 4-tier model utilises a unique heat-dissipating domed lens to achieve maximum LED intensity output over a wider range of environmental conditions.*

*The SL-125-C Complete Lantern Assembly provides a complete solution for visual navigation requirements incorporating solar modules and battery to power the light.*

*Remote monitoring and control capabilities are also available for the SL-125, allowing the performance of the units to be monitored from remote sites. System status includes battery condition, flash characters, operational configuration, and lantern/buoy position.*

*The SL-125 may also be fitted with Comm-Sync. The Sealite Comm-Sync range of lanterns utilises an internal RF module that operates on a 2.4Ghz frequency and has an operational range of up to 1.4km between 2 lights. Should more than two lights be required to be synchronised the range may be extended for longer distances as the lanterns transmit data to the adjacent lantern, causing it to fall in to synchronisation. The only limitation is no lantern should be more than 1.4km from the next lantern in series.*

Table 1.1. SL-125 LED Marine Lantern Series (12v)

Model	Description	Peak Intensity Flashing (cd)	Colour	No. LEDs	Power Amp/hour	Voltage
SL-125-1.R	1-tier LED Lantern	163	Red	36	0.42	12v
SL-125-1.G		200	Green	36	0.32	12v
SL-125-1.W		180	White	36	0.32	12v
SL-125-1.Y		145	Yellow	36	0.42	12v
SL-125-2.R	2-tier LED Lantern	280	Red	72	0.84	12v
SL-125-2.G		328	Green	72	0.64	12v
SL-125-2.W		319	White	72	0.64	12v
SL-125-2.Y		257	Yellow	72	0.84	12v
SL-125-3.R	3-tier LED Lantern	427	Red	108	1.28	12v
SL-125-3.G		518	Green	108	0.96	12v
SL-125-3.W		496	White	108	0.96	12v
SL-125-3.Y		399	Yellow	108	1.28	12v
SL-125-4.R	4-tier LED Lantern	798	Red	144	1.70	12v
SL-125-4.G		1010	Green	144	1.28	12v
SL-125-4.W		940	White	144	1.28	12v
SL-125-4.Y		760	Yellow	144	1.70	12v

Subject to change or variation without notice

**SL-125 Series**

**SPECIFICATIONS\* •**

**SL-125 Series**

**Light Characteristics**

Light Source

SL-125-1: 36 ultra-high intensity LEDs  
SL-125-2: 72 ultra-high intensity LEDs  
SL-125-3: 108 ultra-high intensity LEDs  
SL-125-4: 144 ultra-high intensity LEDs

Available Colours

Red, Green, White, Yellow, Blue

Typical Maximum Intensity (cd)†

Refer to Typical Maximum Intensity Tables for SL-125 lanterns

Visible Range (NM)

AT @ 0.74: 5-9+  
AT @ 0.85: 6.3-12.5+  
360

Horizontal Output (degrees)

9 (SL-125-1, SL-125-2 & SL-125-3)

Vertical Divergence (degrees)

7 (SL-125-4)

Reflector Type

Omnidirectional 360° LED Reflector  
(US Pat. No. 6,667,582. AU Pat. No. 778,918)

Available Flash Characteristics

Up to 256 IALA recommended (user adjustable)

Intensity Adjustments

Adjustable in 25% increments

LED Life Expectancy (hours)

>100,000

**Electrical Characteristics**

Current Draw (mA)

Refer to Sealite Power Calculator

Circuit Protection

Integrated

Nominal Voltage (V)

12

Temperature Range

-40 to 80°C

**Physical Characteristics**

Body Material

LEXAN® Polycarbonate – UV-stabilised

Lens Material

LEXAN® Polycarbonate – UV-stabilised

Lens Diameter (mm/inches)

150 / 5<sup>7</sup>/<sub>8</sub>

Lens Design

External optics with interior flute design

Mounting

3 & 4 hole 200mm bolt pattern

Height (mm/inches)

SL-125-1: 205 / 8<sup>1</sup>/<sub>8</sub>

SL-125-2: 240 / 9<sup>1</sup>/<sub>2</sub>

SL-125-3: 240 / 9<sup>1</sup>/<sub>2</sub>

SL-125-4: 240 / 9<sup>1</sup>/<sub>2</sub>

231 / 9<sup>1</sup>/<sub>8</sub>

Width (mm/inches)

From 1.1 / 2<sup>3</sup>/<sub>8</sub>

Mass (kg/lbs)

Up to 12 years

Product Life Expectancy

**Certifications**

CE

EN61000-6-3:2001. EN61000-6-1:2001. EN55022.

EN61000-4-2:1995. EN61000-4-3:2002

USCG specification HSCG23-05-R-E43013, including Change 1.

IALA

Signal colours compliant to IALA E-200-1

Quality Assurance

ISO9001:2008

Waterproof

IP68

**Intellectual Property**

Patents

US Pat. No. 6,667,582. AU Pat. No. 778,918

Trademarks

SEALITE® is a registered trademark of Sealite Pty Ltd

**Warranty\* •**

3 years

**Options Available**

- GPS Synchronisation
- Hard-wire Synchronisation
- AIS Remote Monitoring
- GSM Monitoring & Control System
- Additional cable
- 10 degree lens (SL-125-1)



• Specifications subject to change or variation without notice  
\* Subject to standard terms and conditions  
† Intensity setting subject to solar availability

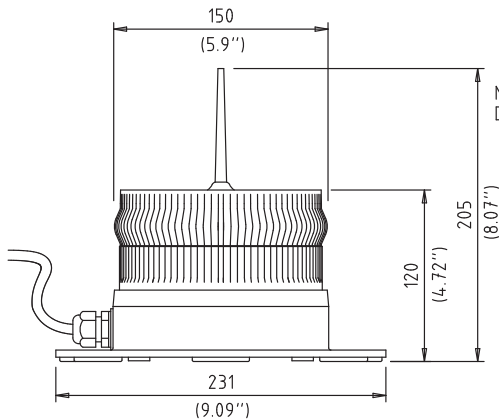

**Figure 1.1.**  
**SL-125-1**

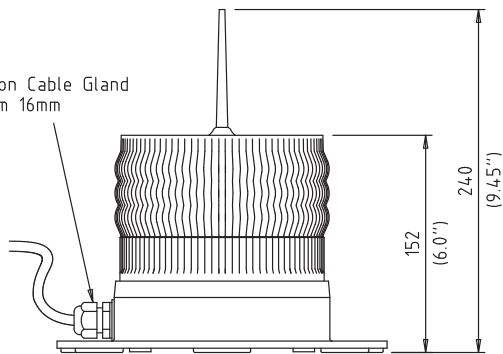

**Figure 1.2.**  
**SL-125-2 & SL-125-3**

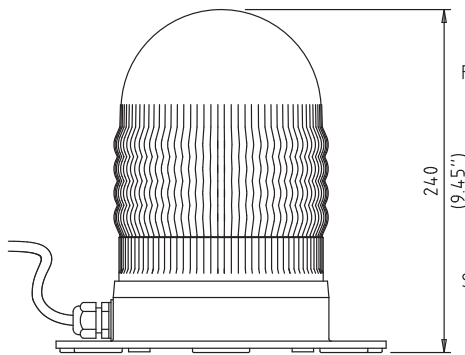

**Figure 1.3.**  
**SL-125-4**

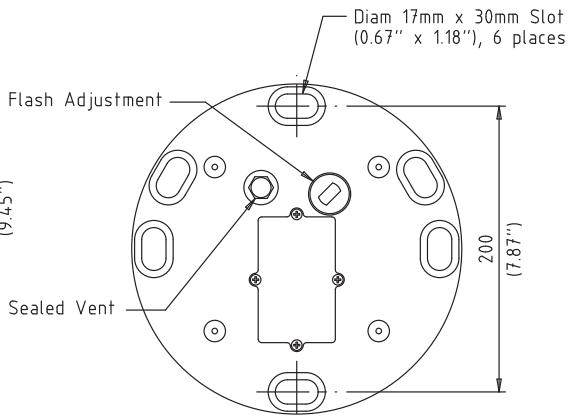

**Figure 1.4.**  
**Base (all models)**

## SL-125 Complete Available Configurations

The SL-125 models outlined in Table 1.1 are available in a range of complete lantern assemblies.

1x (fixed installations) or 2x (buoy installations) 20watt solar modules may be fitted to the lantern as standard to provide a complete solution for visual navigation requirements.

The lantern may also be equipped with up to 2x 40watt solar modules to power longer-range requirements or ancillary equipment.

**Table 1.2. SL-125-C Type 1 Complete Lantern Assemblies**

Model	Description
<b>SL-125-1/C-1</b>	SL-125 1-Tier. Complete Lantern Assembly. Single 20w Solar Module.
<b>SL-125-1/C-2</b>	SL-125 1-Tier. Complete Lantern Assembly. Dual 20w Solar Module.
<b>SL-125-2/C-1</b>	SL-125 2-Tier. Complete Lantern Assembly. Single 20w Solar Module.
<b>SL-125-2/C-2</b>	SL-125 2-Tier. Complete Lantern Assembly. Dual 20w Solar Module.

**Table 1.3. SL-125-C Type 2 Complete Lantern Assemblies**

Model	Description
<b>SL-125-1/C-1.T2</b>	SL-125 1-Tier. Complete Lantern Assembly. Single 40w Solar Module.
<b>SL-125-1/C-2.T2</b>	SL-125 1-Tier. Complete Lantern Assembly. Dual 40w Solar Module.
<b>SL-125-2/C-1.T2</b>	SL-125 2-Tier. Complete Lantern Assembly. Single 40w Solar Module.
<b>SL-125-2/C-2.T2</b>	SL-125 2-Tier. Complete Lantern Assembly. Dual 40w Solar Module.
<b>SL-125-3/C-1.T2</b>	SL-125 3-Tier. Complete Lantern Assembly. Single 40w Solar Module.
<b>SL-125-3/C-2.T2</b>	SL-125 3-Tier. Complete Lantern Assembly. Dual 40w Solar Module.
<b>SL-125-4/C-1.T2</b>	SL-125 4-Tier. Complete Lantern Assembly. Single 40w Solar Module.
<b>SL-125-4/C-2.T2</b>	SL-125 4-Tier. Complete Lantern Assembly. Dual 40w Solar Module.



**SL-125 Type 1 Complete**

**SPECIFICATIONS\* \***

**SL-125-C Type 1**

**Light Characteristics**

Light Source  
Available Colours  
Typical Maximum Intensity (cd)†  
Visible Range (NM)

Horizontal Output (degrees)  
Vertical Divergence (degrees)  
Reflector Type

Available Flash Characteristics  
Intensity Adjustments  
LED Life Expectancy (hours)

**Electrical Characteristics**

Current Draw (mA)  
Circuit Protection  
Nominal Voltage (V)  
Autonomy (days)  
Temperature Range

**Solar Characteristics**

Solar Module Type  
Output (watts)

Charging Regulation

**Power Supply**

Battery Type  
Battery Capacity (Ah)  
Nominal Voltage (V)

**Physical Characteristics**

Body Material  
Lens Material  
Lens Diameter (mm/inches)  
Lens Design  
Mounting  
Height (mm/inches)  
Width (mm/inches)  
Mass (kg/lbs)  
Product Life Expectancy

**Certifications**

CE

IALA

Quality Assurance  
Waterproof

**Intellectual Property**

Patents  
Trademarks

**Warranty \***

**Options Available**

SL-125-1 or SL-125-2  
Red, Green, White, Yellow, Blue  
Refer to Typical Maximum Intensity Table for SL-125-1 or SL-125-2  
AT @ 0.74: 5-7+  
AT @ 0.85: 6.3-9.3+  
360  
9  
Omnidirectional 360° LED Reflector  
(US Pat. No. 6,667,582. AU Pat. No. 778,918)  
Up to 256 IALA recommended (user adjustable)  
Adjustable in 25% increments  
>100,000

Refer to Sealite Power Calculator  
Reverse polarity  
12  
>20 (14 hour darkness, 12.5% duty cycle)  
-40 to 80°C

Multicrystalline  
20 (SL-125-1-CT1-1 and SL-125-2-CT1-1 configurations)  
40 (SL-125-1-CT1-2 and SL-125-2-CT1-2 configurations)  
Microprocessor controlled

Gel SLA  
26  
12

7-stage powder-coated aluminium  
LEXAN® Polycarbonate – UV-stabilised  
150 / 5<sup>7</sup>/<sub>8</sub>  
External optics with interior flute design  
200mm bolt pattern  
From 665 / 26<sup>1</sup>/<sub>4</sub>  
656 / 25<sup>3</sup>/<sub>4</sub>  
From 18 / 39<sup>5</sup>/<sub>8</sub>  
Up to 12 years

EN61000-6-3:2001. EN61000-6-1:2001. EN55022. EN61000-4-2:1995.  
EN61000-4-3:2002  
USCG specification HSCG23-05-R-E43013, including Change 1.  
Signal colours compliant to IALA E-200-1  
ISO9001:2008  
IP68 light head. IP66 battery compartment

US Pat. No. 6,667,582. AU Pat. No. 778,918  
SEALITE® is a registered trademark of Sealite Pty Ltd  
3 years

- Single or dual solar module(s)
- GPS Synchronisation
- Hard-wire Synchronisation
- GSM Monitoring & Control System
- 10 degree lens (SL-125-1)
- 40 watt panels



• Specifications subject to change or variation without notice  
\* Subject to standard terms and conditions  
† Intensity setting subject to solar availability

## SL-125 Type 2 Complete

### SPECIFICATIONS\* \*

### SL-125-C Type 2

#### Light Characteristics

Light Source  
Available Colours  
Typical Maximum Intensity (cd)†  
Visible Range (NM)

Horizontal Output (degrees)  
Vertical Divergence (degrees)  
Reflector Type

Available Flash Characteristics  
Intensity Adjustments  
LED Life Expectancy (hours)

#### Electrical Characteristics

Current Draw (mA)  
Circuit Protection  
Nominal Voltage (V)  
Autonomy (days)  
Temperature Range

#### Solar Characteristics

Solar Module Type  
Output (watts)

Charging Regulation

#### Power Supply

Battery Type  
Battery Capacity (Ah)  
Nominal Voltage (V)

#### Physical Characteristics

Body Material  
Lens Material  
Lens Diameter (mm/inches)  
Lens Design  
Mounting  
Height (mm/inches)  
Width (mm/inches)  
Mass (kg/lbs)  
Product Life Expectancy

#### Certifications

CE

IALA  
Quality Assurance  
Waterproof

#### Intellectual Property

Patents  
Trademarks

#### Warranty \*

#### Options Available

SL-125-1 or SL-125-2  
Red, Green, White, Yellow, Blue  
Refer to Typical Maximum Intensity Table for SL-125-1 or SL-125-2  
AT @ 0.74: 5-7+  
AT @ 0.85: 6.3-9.3+  
360  
9  
Omnidirectional 360° LED Reflector  
(US Pat. No. 6,667,582. AU Pat. No. 778,918)  
Up to 256 IALA recommended (user adjustable)  
Adjustable in 25% increments  
>100,000

Refer to Sealite Power Calculator  
Reverse polarity  
12  
>20 (14 hour darkness, 12.5% duty cycle)  
-40 to 80°C

Multicrystalline  
40 (SL-125-1-CT2-1, SL-125-2-CT2-1, SL-125-3-CT2-1 and SL-125-4-CT2-1)  
80 (SL-125-1-CT2-2, SL-125-2-CT2-2, SL-125-3-CT2-2 and SL-125-4-CT2-2)  
Microprocessor controlled

Gel SLA  
55  
12

7-stage powder-coated aluminium  
LEXAN® Polycarbonate – UV-stabilised  
150 / 5<sup>7</sup>/<sub>8</sub>  
External optics with interior flute design  
200mm bolt pattern  
From 570 / 22<sup>1</sup>/<sub>2</sub>  
665 / 26<sup>1</sup>/<sub>4</sub>  
From 45 / 99<sup>1</sup>/<sub>4</sub>  
Up to 12 years

EN61000-6-3:2001. EN61000-6-1:2001. EN55022. EN61000-4-2:1995.  
EN61000-4-3:2002  
USCG specification HSCG23-05-R-E43013, including Change 1.  
Signal colours compliant to IALA E-200-1  
ISO9001:2008  
IP68 light head. IP66 battery compartment

US Pat. No. 6,667,582. AU Pat. No. 778,918  
SEALITE® is a registered trademark of Sealite Pty Ltd  
3 years

- SL-155 Series Lantern
- Single or dual solar module(s)
- 100Ah battery
- 60watt solar module (single or dual configuration)
- GPS Synchronisation
- Hard-wire Synchronisation
- AIS Remote Monitoring
- GSM Monitoring & Control System
- Extended base post
- 10 degree lens (SL-125-1)

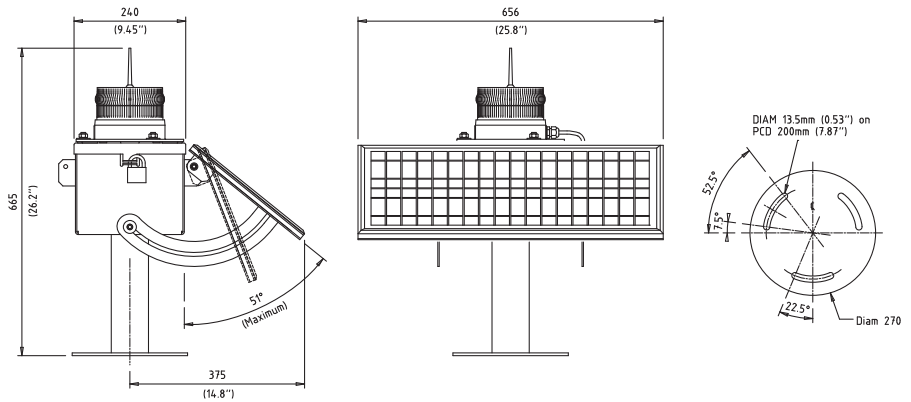

**Figure 2.1.**  
**SL-125-1/C-1**

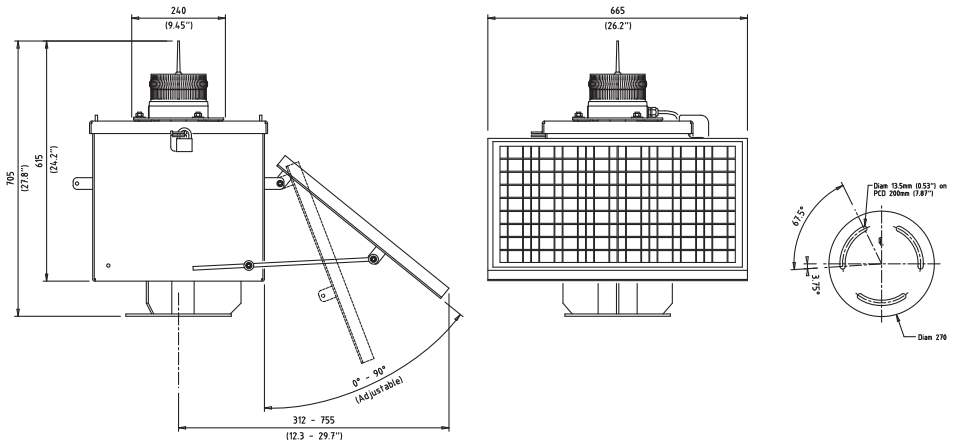

**Figure 2.2.**  
**SL-125-1/C-1.T2**



## **Optional Configurations**

### **RF Synchronisation (SL-125-CS)**

The SL-125 may be fitted with optional comm sync RF module for short range flash synchronisation - ideal for marina entrances and aquaculture applications.

### **GPS Synchronisation (SL-125-GPS)**

For flash synchronisation of lanterns installed over longer ranges, a GPS module may be fitted.

When lanterns flash in synchronisation they can be clearly distinguished from other nav aids and confusing background lighting - ideal for rivers and channel marking.

### **GSM Monitoring & Control (SL-125-GSM) and AIS Integration (SL-125-AIS)**

The SL-125 lantern series may also be fitted with GSM remote monitoring and control capabilities - enabling users to access real-time diagnostics data and change lantern settings via cell-phone.

AIS integration enables remote monitoring of the SL-125 lantern as well as crucial Message 21 information to be broadcast to mariners within the region.

### **Radio Control (SL-125-RC)**

Radio control may be fitted to SL-125 series products enabling users to remotely modify the setup of their lantern via handheld radio controller (SL-RC-2.4).

For example, the operator can remotely change between different coloured LED banks (to change the colour of the light), turn their lights ON and OFF, or change the flash setting. Perfect for remote traffic control and to designate an area of activity.



## Installation

### Settings of SL-125 & SL-125-C Models

Before installing the light, intensity and flash settings must be set.

1. Remove the bolt/lock securing the battery box lid, and open unit (SL-125-C ONLY).
2. Remove the bung from the base of the SL-125 light.
3. The power and range settings of the lantern are adjusted by setting the DIP switches inside the lantern. Your lantern is normally set to maximum range (see 'Selecting Intensity/Power Setting' section of this manual).
4. Set rotary switches to the required flash code (see 'Selecting a Flash Code' section of this manual).
5. Replace bung.
6. A sealed vent on the base allows air transfer without moisture intake, and should not be disturbed.

**Note:** *Lantern is activated by connecting positive and negative battery wires (and solar module wires for SL-125-C).*

### Activation and Installation of SL-125

1. Battery Connection: Connect "Battery Positive (+)" wire to positive terminal of battery, and "Battery Negative (-)" wire to negative terminal of battery.  
Mains Connection: Connect positive and negative wires to 12volt power supply (ONLY).
2. To test place dark cover (towel or jacket) on top of light to activate sensor, light will come on within one minute.
3. Ensure that the unit is bolted to an even, flat surface.

### Activation and Installation of SL-125-C

1. Inside the battery box is an internal battery container. To access the battery, remove the four screws and lid of this internal container.
2. Connect the "Battery Negative (-)" wire to the negative terminal of the battery, and the "Battery Positive (+)" wire to the positive terminal of the battery.
3. Connect the "Battery Positive (+)" and "Battery Negative (-)" wires from the Solar Regulator to the battery.
4. Replace the internal battery container lid and screws making sure no wires are protruding.
5. Close the battery box lid and secure with bolt/lock. Light is now activated.
6. To test place dark cover (towel or jacket) on top of light to activate sensor, light will come on within one minute.
7. Ensure that the unit is bolted to an even, flat surface.

**Care must be taken to observe the polarity of each wire before they are connected.**

**Note:** *Refer to 'Lantern Status' section of this manual to check the status of the light after activated. Indicated by red and yellow status LED's viewed at the base of the lens.*

## Selecting an Intensity/Power Setting

Intensity/power settings on Sealite lanterns operate via DIP switches, located near the rotary switches on the flasher unit. The intensity/power settings may be used to reduce the power consumption and intensity of the lantern. Setting the lantern to 25% intensity will reduce the power consumption to 25% of the normal 100% setting and the range by 20% - 40% depending on the maximum intensity. Refer to Sealite power calculator to confirm reduced range. This setting may be used to adjust the current draw of the light to local sunlight conditions.

The following diagrams indicate intensity/power settings:-

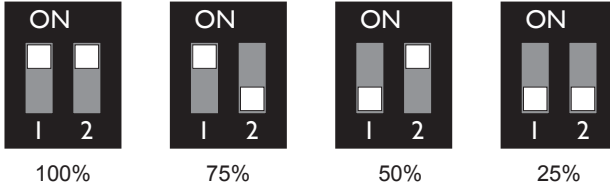

## Selecting a Flash Code - Rotary Switches A & B

All lanterns have 2 rotary switches marked A and B on the flasher unit. Turning the small arrows to the appropriate number or letter will set the code. The unit will respond within 30 seconds to activate a new flash code. A comprehensive list of available flash codes is listed on in the 'Flash Codes' section of this manual.

Example:

SWITCH		FLASH CODE	ON	OFF
A	B			
A	0	FL 3 S	0.3	2.7

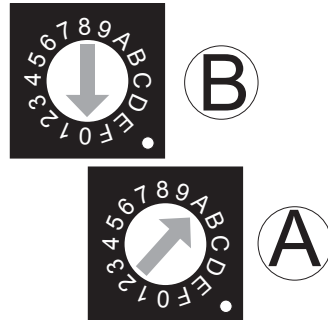



## **RF Synchronisation (Comm-Sync) Option**

Sealite's innovative RF Synchronisation System is designed to offer a low-cost short range flash synchronisation option for applications including rivers, estuaries, marina entrances, channel marking and aquaculture.

RF Synchronisation may be fitted to the SL-125 range of lanterns and benefits vessel operators at night by illuminating the boundary or channel as a clear passage on entrance, as opposed to indiscriminant flashing lights which may render the judgment of distance difficult.

### **Operating Principle**

RF Comm-Sync products are fitted with an internal RF module, which operates on a 2.4GHz frequency and has an operational range of 1.4km between 2 lights.

Should more than 2 lanterns be required to be synchronised the range may be extended for longer distances as each lantern transmits the data to all adjacent lanterns - causing them to fall into synchronisation. The only limitation is that no lantern should be more than 1.4km from the next lantern in the series.

RF Comm-Sync lanterns operate within a peer-to-peer network topology and therefore are not dependent upon master/slave relationships. This means that lights remain synchronised without use of master/slave configurations and each lantern in the network shares both the roles of master and slave.

Using innovative software, the additional power consumption is minimal, and in most configurations the solar lantern requires only 1.5hrs of direct sunlight per day to retain full working autonomy.

***Synchronisation is recommended for lanterns operating with up to 20% duty cycles and in regions where typical solar irradiation averages 1.5Kwh per day. Flash characters exceeding this may require lantern intensity adjustment.***

***Synchronisation is achieved via short-range RF communication between lanterns, and relies on line-of-sight operation.***

### **Setup**

To enable flash synchronisation of independent RF Comm-Sync lanterns, set lanterns to the same flash characteristic (see "Selecting a Flash Code" section of this manual).

**IMPORTANT: *only lights set to the exact same flash pattern/code will flash in synchronisation.***



## **GPS Synchronisation Option**

This GPS option can be added to any of the SL-125 series lanterns previously outlined, and provides the user with the ability to install independently operating lanterns that all flash in synchronisation.

No additional power supplies, aerials or control systems are required, and with its microprocessor-based system, the GPS option is specifically designed to provide maximum reliability and performance over a wide range of environmental conditions.

### **Operating Principle**

Each light operates independently and requires no operator intervention. A minimum of 4 satellites need to be in view for the built-in GPS receiver to collect time data. At dusk, the light sensor will turn the light on. If time data is available the light will come on synchronised to every other light with the same selected flash code.

Synchronisation is achieved using an internal algorithm based on the highly accurate time base and time data received from the satellites. The satellite data is provided from a number of earth stations using atomic clocks as the time base. Continuous self-checking ensures that the light will continue to run in synchronisation.

### **Light Activation**

At power-up the microprocessor checks that the internal GPS module is programmed correctly and is able to provide valid time base and time data.

Once outside with a clear view of the sky, valid data should become available within 20 minutes.

### **Daylight Operation**

During daylight hours the microprocessor is in idle mode to reduce power consumption. Time data continues to be updated once per second. The microprocessor will automatically exit the idle mode as soon as dark conditions are detected.

### **Dark Operation**

When dark conditions are detected the light:

- Checks for valid time data and is turned on after a delay based on the current time and the length of the selected flash code;
- If valid time data is not detected the light will turn on after approximately 10 seconds. This light will not be synchronised.
- If the light turns on unsynchronised it will continually check for valid time data. Once valid data is found the light will automatically synchronise.

**Note:** Lights will not synchronise if different flash codes are selected.



## Lantern Status

Two status LED's on the main printed circuit board (position A in image below) provide the operator with an indication of the lantern status.

There is one red and one yellow status LED. The red status LED is used to indicate the health of the lantern's power system. The yellow status LED is used to indicate the operational status of the lantern.

These indicator LED's can be viewed at the base of the lens. Separate indicator LEDs are located on the top of the GPS circuit board (where fitted- see position B & C of figure 3.1.).

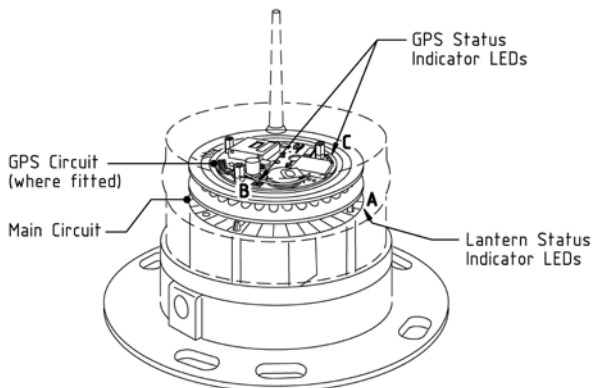

**Figure 3.1.**

All Sealite boards are fitted with two Indicator LED's. These are positioned near the Flash Code Rotary Switches. Use the table below to help determine operational status.

Yellow LED	Lantern Status	Lantern	Comment
OFF	Normal	OFF	Lantern is in Daylight and in Dusk till Dawn mode or in Standby Mode
Flashing ON 0.15 seconds OFF 0.15 seconds	Normal	OFF	Light is activating and will turn on after detecting 30 seconds of continuous darkness.
Flashing 2 x quick flashes every 2 seconds (Heartbeat)	Normal	ON	Lantern is in Normal operating condition. It is not connected to any GPS synchronisation.
Flashing ON 1.5 seconds OFF 1.5 seconds	Normal	ON	Normal operating condition. Lantern is synchronised to GPS-enabled lanterns.
Flashing 1 x quick flash every 2 seconds	Normal	ON	Lantern is 're-syncing' with GPS. The lantern re-sync's with the GPS every 15 minutes.
Flashing 2 x quick flashes every 11 seconds	Normal	ON	Lantern is a Hard Wire Synchronisation Slave.

Red LED	Lantern Status	Lantern	Comment
OFF	Normal		Normal Battery Voltage
Flashing once every 1.6 seconds	Battery Voltage is 12 – 12.5V		Battery Voltage is between 12 – 12.5V
Flashing twice every 2 seconds	Battery Voltage is 11.5 – 12V		Battery Voltage is between 11.5 – 12V
Flashing 3 x times every 2 seconds	Battery Voltage is 10.5 – 11.5V		Battery Voltage is between 10.5 – 11.5V
Flashing 4 x times every 2.5 seconds	Battery Voltage is 10.0 – 10.5V		Battery Voltage is between 10.0 – 10.5V
Flashing 5 x times every 3 seconds	Battery Voltage is less than 10.0V		Battery Voltage is at less than 10.0V
Fixed-on	Flat Battery (<10V)	OFF	Flat Battery cut-off is now operational and the lantern will be off. Battery must receive charge (above 12V) and lantern must see daylight for at least 1 minute before resuming normal operation.
Flashing ON 1.5 seconds OFF 1.5 seconds	Battery Voltage is above 13.5V		Battery Voltage is above 13.5V. this may indicate a problem with the solar regulator.

## Flash Codes

The Sealite SL-125 Series may be set to any of 256 IALA recommended flash settings which are user-adjustable onsite without the need for external devices.

**SEALITE® code reference is listed by number of flashes**

**For the latest version of this document visit [www.sealite.com](http://www.sealite.com)  
or email [info@sealite.com](mailto:info@sealite.com)**

### Symbols

FL	Flash followed by number Eg. FL 1 S, one flash every second
F	Fixed
Q	Quick flash
VQ	Very quick flash
OC	Occulting; greater period on than off
ISO	Isophase; equal period on and off
LFL	Long flash long
MO	Morse code ( ) contains letter

For example, VQ (6) + LFL 10 S means 6 very quick flashes followed by a long flash, during a 10-second interval.

The amount of power your lantern draws through the night depends on the duty cycle, i.e. the amount of time on as a proportion to the timing cycle. For example, 0.5 seconds on and 4.5 seconds off equals a 10% duty cycle.

It is best to operate at the lowest duty cycle appropriate to the actual needs of the application.

### Recommended Rhythm for Flashing Light - IALA Regions A and B

MARK DESCRIPTION	RHYTHM
<b>Port Hand &amp; Starboard Marks:</b>	Any, other than Composite Group Flashing (2+1)
<b>Preferred Channel Starboard:</b>	Composite Group Flashing (2+1)
<b>Preferred Channel Port:</b>	Composite Group Flashing (2+1)
<b>North Cardinal Mark:</b>	Very quick or quick
<b>East Cardinal Mark:</b>	Very quick (3) every 5 seconds or quick (3) every 10 seconds
<b>South Cardinal Mark:</b>	Very quick (6) + long flash every 10 seconds or quick (6) + long flash every 15 seconds
<b>West Cardinal Mark:</b>	Very quick (9) every 10 seconds or quick (9) every 15 seconds
<b>Isolated Danger Mark:</b>	Group flashing (2)
<b>Safe Water Mark:</b>	Isophase, occulting, one long flash every 10 seconds or Morse Code "A"
<b>Special Marks:</b>	Any, other than those described for Cardinal, Isolated Danger or Safe Water Marks

SWITCH	FLASH CODE	ON	OFF
A	B		
0	0 F (Steady light)		
D	3 VQ 0.5 S	0.2	0.3
E	3 VQ 0.6 S	0.2	0.4
F	3 VQ 0.6 S	0.3	0.3
7	3 Q 1 S	0.2	0.8
8	3 Q 1 S	0.3	0.7
9	3 Q 1 S	0.4	0.6
A	3 Q 1 S	0.5	0.5
8	4 Q 1 S	0.8	0.2
B	3 Q 1.2 S	0.3	0.9
9	4 Q 1.2 S	0.5	0.7
C	3 Q 1.2 S	0.6	0.6
F	4 FL 1.5 S	0.2	1.3
1	0 FL 1.5 S	0.3	1.2
0	5 FL 1.5 S	0.4	1.1
0	4 FL 1.5 S	0.5	1.0
2	0 FL 2 S	0.2	1.8
3	0 FL 2 S	0.3	1.7
4	0 FL 2 S	0.4	1.6
5	0 FL 2 S	0.5	1.5
6	0 FL 2 S	0.7	1.3
7	0 FL 2 S	0.8	1.2
1	2 ISO 2 S	1.0	1.0
8	0 FL 2.5 S	0.3	2.2
9	0 FL 2.5 S	0.5	2.0
D	6 FL 2.5 S	1.0	1.5
1	5 FL 3 S	0.2	2.8
A	0 FL 3 S	0.3	2.7
2	5 FL 3 S	0.4	2.6
B	0 FL 3 S	0.5	2.5
3	5 FL 3 S	0.6	2.4
C	0 FL 3 S	0.7	2.3
D	0 FL 3 S	1.0	2.0
2	2 ISO 3 S	1.5	1.5
5	4 OC 3 S	2.0	1.0
E	2 OC 3 S	2.5	0.5
4	6 OC 3.5 S	2.5	1.0
4	5 FL 4 S	0.2	3.8
5	5 FL 4 S	0.3	3.7
E	0 FL 4 S	0.4	3.6
F	0 FL 4 S	0.5	3.5
6	5 FL 4 S	0.6	3.4
0	1 FL 4 S	0.8	3.2
1	1 FL 4 S	1.0	3.0
2	1 FL 4 S	1.5	2.5
3	2 ISO 4 S	2.0	2.0
3	6 OC 4 S	2.5	1.5
F	2 OC 4 S	3.0	1.0
3	1 FL 4.3 S	1.3	3.0
8	5 FL 5 S	0.2	4.8
4	1 FL 5 S	0.3	4.7
5	1 FL 5 S	0.5	4.5
9	5 FL 5 S	0.9	4.1
6	1 FL 5 S	1.0	4.0

SWITCH	FLASH CODE	ON	OFF
A	B		
7	1 FL 5 S	1.5	3.5
4	2 ISO 5 S	2.5	2.5
8	2 LFL 5 S	2.0	3.0
0	3 OC 5 S	3.0	2.0
1	3 OC 5 S	4.0	1.0
2	3 OC 5 S	4.5	0.5
C	6 FL 6 S	0.2	5.8
B	5 FL 6 S	0.3	5.7
C	5 FL 6 S	0.4	5.6
8	1 FL 6 S	0.5	5.5
9	1 FL 6 S	0.6	5.4
A	1 FL 6 S	1.0	5.0
7	5 FL 6 S	1.2	4.8
B	1 FL 6 S	1.5	4.5
5	2 ISO 6 S	3.0	3.0
9	2 LFL 6 S	2.0	4.0
6	4 OC 6 S	4.0	2.0
3	3 OC 6 S	4.5	1.5
4	3 OC 6 S	5.0	1.0
A	4 FL 7 S	1.0	6.0
9	6 FL 7 S	2.0	5.0
5	6 OC 7 S	4.5	2.5
D	5 FL 7.5 S	0.5	7.0
C	1 FL 7.5 S	0.8	6.7
E	5 FL 8 S	0.5	7.5
B	4 FL 8 S	1.0	7.0
6	2 ISO 8 S	4.0	4.0
A	2 LFL 8 S	2.0	6.0
6	6 OC 8 S	5.0	3.0
B	2 LFL 8 S	3.0	5.0
F	5 FL 9 S	0.9	8.1
C	4 FL 9 S	1.0	8.0
7	6 OC 9 S	6.0	3.0
0	6 FL 10 S	0.2	9.8
1	6 FL 10 S	0.3	9.7
D	1 FL 10 S	0.5	9.5
2	6 FL 10 S	0.8	9.2
E	1 FL 10 S	1.0	9.0
1	4 FL 10 S	1.5	8.5
C	2 LFL 10 S	2.0	8.0
D	2 LFL 10 S	3.0	7.0
7	2 ISO 10 S	5.0	5.0
2	4 LFL 10 S	4.0	6.0
8	6 OC 10 S	6.0	4.0
5	3 OC 10 S	7.0	3.0
6	3 OC 10 S	7.5	2.5
F	1 FL 12 S	1.2	10.8
D	4 FL 12 S	2.5	9.5
3	4 LFL 12 S	2.0	10.0
0	2 FL 15 S	1.0	14.0
4	4 LFL 15 S	4.0	11.0
7	4 OC 15 S	10	5.0
A	6 LFL 20 S	2.0	18.0
E	4 FL 26 S	1.0	25.0

SWITCH	FLASH CODE	ON	OFF	ON	OFF
<b>A</b>	<b>B</b>				
0	A FL (2) 4 S	0.5	1.0	0.5	2.0
E	B VQ (2) 4 S	0.2	1.0	0.2	2.6
1	A FL (2) 4.5 S	0.3	1.0	0.3	2.9
2	A FL (2) 4.5 S	0.4	1.0	0.4	2.7
3	A FL (2) 4.5 S	0.5	1.0	0.5	2.5
F	9 FL (2) 5 S	0.2	0.8	0.2	3.8
2	C FL (2) 5 S	0.2	1.2	0.2	3.4
4	A FL (2) 5 S	0.4	0.6	0.4	3.6
0	7 FL (2) 5 S	0.5	1.0	0.5	3.0
1	7 FL (2) 5 S	1.0	1.0	1.0	2.0
9	B Q (2) 5 S	0.3	0.7	0.3	3.7
2	9 Q (2) 5 S	0.5	0.5	0.5	3.5
5	A FL (2) 5.5 S	0.4	1.4	0.4	3.3
7	8 FL (2) 6 S	0.3	0.6	1.0	4.1
A	A FL (2) 6 S	0.3	0.9	0.3	4.5
6	A FL (2) 6 S	0.3	1.0	0.3	4.4
7	A FL (2) 6 S	0.4	1.0	0.4	4.2
9	9 FL (2) 6 S	0.5	1.0	0.5	4.0
2	8 FL (2) 6 S	0.8	1.2	0.8	3.2
3	7 FL (2) 6 S	1.0	1.0	1.0	3.0
3	9 Q (2) 6 S	0.3	0.7	0.3	4.7
A	9 FL (2) 7 S	1.0	1.0	1.0	4.0
7	B FL (2) 8 S	0.4	0.6	2.0	5.0
8	A FL (2) 8 S	0.4	1.0	0.4	6.2
4	7 FL (2) 8 S	0.5	1.0	0.5	6.0
8	8 FL (2) 8 S	0.8	1.2	2.4	3.6
5	7 FL (2) 8 S	1.0	1.0	1.0	5.0
4	C OC (2) 8 S	3.0	2.0	1.0	2.0
5	C OC (2) 8 S	5.0	1.0	1.0	1.0
F	B VQ (2) 8 S	0.2	1.0	0.2	6.6
9	A FL (2) 10 S	0.4	1.6	0.4	7.6
6	7 FL (2) 10 S	0.5	1.0	0.5	8.0
7	7 FL (2) 10 S	0.5	1.5	0.5	7.5
6	9 FL (2) 10 S	0.5	2.0	0.5	7.0
8	7 FL (2) 10 S	0.8	1.2	0.8	7.2
B	9 FL (2) 10 S	1.0	1.0	1.0	7.0
9	7 FL (2) 10 S	1.0	1.5	1.0	6.5
4	9 Q (2) 10 S	0.6	0.4	0.6	8.4
B	A FL (2) 12 S	0.4	1.0	0.4	10.2
C	9 FL (2) 12 S	0.5	1.0	0.5	10.0
D	9 FL (2) 12 S	1.5	2.0	1.5	7.0
A	8 FL (2) 15 S	0.5	1.5	2.0	11.0
A	7 FL (2) 15 S	1.0	2.0	1.0	11.0
8	B Q (2) 15 S	0.2	0.8	0.2	13.8
C	A FL (2) 20 S	1.0	3.0	1.0	15.0
D	A FL (2) 25 S	1.0	1.0	1.0	22.0

SWITCH	FLASH CODE	ON	OFF	ON	OFF	ON	OFF
<b>A</b>	<b>B</b>						
7	9 Q (3) 5 S	0.5	0.5	0.5	0.5	0.5	2.5
5	9 VQ (3) 5 S	0.2	0.3	0.2	0.3	0.2	3.8
0	C VQ (3) 5 S	0.3	0.2	0.3	0.2	0.3	3.7
E	9 VQ (3) 5 S	0.3	0.3	0.3	0.3	0.3	3.5
3	C FL (3) 6 S	0.5	1.0	0.5	1.0	0.5	2.5
2	B FL (2+1) 6 S	0.3	0.4	0.3	1.2	0.3	3.5

SWITCH	FLASH CODE	ON	OFF	ON	OFF	ON	OFF	
A	B							
A	B	Q (3) 6 S	0.3	0.7	0.3	0.7	0.3	3.7
F	A	FL (3) 8 S	0.5	1.0	0.5	1.0	0.5	4.5
0	B	FL (3) 9 S	0.3	1.0	0.3	1.0	0.3	6.1
B	7	FL (3) 9 S	0.8	1.2	0.8	1.2	0.8	4.2
B	8	FL (3) 10 S	0.3	0.7	0.3	0.7	0.9	7.1
C	8	FL (3) 10 S	0.4	0.6	0.4	0.6	1.2	6.8
C	B	FL (3) 10 S	0.5	0.5	0.5	0.5	0.5	7.5
C	7	FL (3) 10 S	0.5	1.5	0.5	1.5	0.5	5.5
D	B	FL (3) 10 S	0.6	0.6	0.6	0.6	0.6	7.0
D	7	FL (3) 10 S	1.0	1.0	1.0	1.0	1.0	5.0
3	8	FL (2+1) 10 S	0.5	0.7	0.5	2.1	0.5	5.7
8	9	OC (3) 10 S	5.0	1.0	1.0	1.0	1.0	1.0
B	B	Q (3) 10 S	0.3	0.7	0.3	0.7	0.3	7.7
D	8	FL (2 + 1) 10 S	0.5	0.5	0.5	0.5	1.5	6.5
1	B	FL (3) 12 S	0.5	1.5	0.5	1.5	0.5	7.5
E	A	FL (3) 12 S	0.5	2.0	0.5	2.0	0.5	6.5
E	7	FL (3) 12 S	0.8	1.2	0.8	1.2	0.8	7.2
B	6	FL (3) 12 S	1.0	1.0	1.0	3.0	1.0	5.0
4	8	FL (2+1) 12 S	0.8	1.2	0.8	2.4	0.8	6.0
5	8	FL (2+1) 12 S	1.0	1.0	1.0	4.0	1.0	4.0
1	8	FL (2+1) 13.5 S	1.0	1.0	1.0	4.0	1.0	5.5
F	7	FL (3) 15 S	0.3	1.7	0.3	1.7	0.3	10.7
9	D	FL (3) 15 S	0.4	1.0	0.4	1.0	0.4	11.8
0	8	FL (3) 15 S	0.5	1.5	0.5	1.5	0.5	10.5
F	8	FL (2+1) 15 S	0.6	0.3	0.6	0.3	1.4	11.8
0	9	FL (2+1) 15 S	0.7	0.5	0.7	0.5	1.9	10.7
1	9	FL (2+1) 15 S	0.7	0.7	0.7	0.7	2.1	10.1
6	8	FL (2+1) 15 S	1.0	2.0	1.0	5.0	1.0	5.0
1	C	VQ (3) 15 S	0.1	0.5	0.1	0.5	0.1	13.7
4	B	FL (3) 20 S	0.5	3.0	0.5	3.0	0.5	12.5
3	B	FL (3) 20 S	0.5	1.5	0.5	1.5	0.5	15.5
5	B	FL (3) 20 S	0.8	1.2	0.8	1.2	0.8	15.2
6	B	FL (3) 20 S	1.0	1.0	1.0	1.0	1.0	15.0

SWITCH	FLASH CODE	ON	OFF	ON	OFF	ON	OFF	ON	OFF
A	B								
B	F	VQ (4) 4 S	0.3	0.3	0.3	0.3	0.3	0.3	2.3
B	D	Q (4) 6 S	0.3	0.7	0.3	0.7	0.3	0.7	2.7
8	D	Q (4) 6 S	0.4	0.6	0.4	0.6	0.4	0.6	2.6
1	D	FL (4) 10 S	0.5	1.0	0.5	1.0	0.5	1.0	5.0
2	D	FL (4) 10 S	0.8	1.2	0.8	1.2	0.8	1.2	3.2
F	E	Q (4) 10 S	0.3	0.7	0.3	0.7	0.3	0.7	6.7
B	E	FL (4) 12 S	0.3	1.7	0.3	1.7	0.3	1.7	5.7
4	F	FL (4) 12 S	0.5	0.5	0.5	0.5	0.5	0.5	8.5
C	E	FL (4) 12 S	0.5	1.5	0.5	1.5	0.5	1.5	5.5
3	D	FL (4) 12 S	0.8	1.2	0.8	1.2	0.8	1.2	5.2
A	D	Q (4) 12 S	0.3	0.7	0.3	0.7	0.3	0.7	8.7
4	D	FL (4) 15 S	0.5	1.5	0.5	1.5	0.5	1.5	8.5
8	E	FL (4) 15 S	1.0	1.0	1.0	1.0	1.0	1.0	8.0
7	D	FL (4) 15 S	1.5	0.5	0.5	0.5	0.5	0.5	10.5
D	E	FL (4) 16 S	0.5	1.5	0.5	1.5	0.5	1.5	9.5
C	D	FL (4) 20 S	0.3	3.0	0.3	3.0	0.3	3.0	9.8
5	D	FL (4) 20 S	0.5	1.5	0.5	1.5	0.5	1.5	13.5
0	D	FL (4) 20 S	0.5	1.5	0.5	1.5	0.5	4.5	10.5
3	F	FL (4) 20 S	1.5	1.5	1.5	1.5	1.5	1.5	9.5
0	F	Q (4) 20 S	0.5	0.5	0.5	0.5	0.5	0.5	16.5
E	E	Q (4) 28 S	0.5	0.5	0.5	0.5	0.5	0.5	24.5
6	F	FL (4) 30 S	0.5	0.5	0.5	0.5	0.5	0.5	26.5

SWITCH	FLASH CODE	ON	OFF	ON	OFF	ON	OFF	ON	OFF	ON	OFF	
A	B											
D	D	Q (5) 7 S	0.3	0.7	0.3	0.7	0.3	0.7	0.3	0.7	0.3	2.7
E	D	Q (5) 10 S	0.3	0.7	0.3	0.7	0.3	0.7	0.3	0.7	0.3	5.7
E	8	FL (5) 12 S	0.5	1.5	0.5	1.5	0.5	1.5	0.5	1.5	0.5	3.5
5	F	FL (5) 20 S	0.5	0.5	0.5	0.5	0.5	0.5	0.5	0.5	0.5	15.5
9	F	FL (5) 20 S	0.8	1.2	0.8	1.2	0.8	1.2	0.8	1.2	0.8	11.2
9	E	FL (5) 20 S	1.0	1.0	1.0	1.0	1.0	1.0	1.0	1.0	1.0	11.0

SWITCH	FLASH CODE	ON	OFF	ON	OFF	ON	OFF	ON	OFF	ON	OFF	ON	OFF	
A	B													
F	D	Q (6) 10 S	0.3	0.7	0.3	0.7	0.3	0.7	0.3	0.7	0.3	0.7	0.3	4.7
A	F	FL (6) 15 S	0.3	0.7	0.3	0.7	0.3	0.7	0.3	0.7	0.3	0.7	0.3	9.7
7	F	FL (6) 15 S	0.5	1.0	0.5	1.0	0.5	1.0	0.5	1.0	0.5	1.0	0.5	7.0

SWITCH	FLASH CODE	ON	OFF	ON	OFF	ON	OFF	ON	OFF	ON	OFF	ON	OFF	ON	OFF	
A	B															
6	E	VQ (6) + LFL 10 S	0.2	0.3	0.2	0.3	0.2	0.3	0.2	0.3	0.2	0.3	0.2	0.3	2.0	5.0
7	E	VQ (6) + LFL 10 S	0.3	0.3	0.3	0.3	0.3	0.3	0.3	0.3	0.3	0.3	0.3	0.3	2.0	4.4
2	F	Q (6) + LFL 15 S	0.2	0.8	0.2	0.8	0.2	0.8	0.2	0.8	0.2	0.8	0.2	0.8	2.0	7.0
2	E	Q (6) + LFL 15 S	0.3	0.7	0.3	0.7	0.3	0.7	0.3	0.7	0.3	0.7	0.3	0.7	2.0	7.0
3	E	Q (6) + LFL 15 S	0.6	0.6	0.6	0.6	0.6	0.6	0.6	0.6	0.6	0.6	0.6	0.6	2.0	5.8
8	F	VQ (6) + LFL 15 S	0.3	0.3	0.3	0.3	0.3	0.3	0.3	0.3	0.3	0.3	0.3	0.3	2.0	9.4

SWITCH	FLASH CODE	ON	OFF	ON	OFF	ON	OFF	ON	OFF	ON	OFF	ON	OFF	ON	OFF	ON	OFF	ON	OFF	
A	B																			
4	E	VQ (9) 10 S	0.2	0.3	0.2	0.3	0.2	0.3	0.2	0.3	0.2	0.3	0.2	0.3	0.2	0.3	0.2	0.3	0.2	5.8
5	E	VQ (9) 10 S	0.3	0.3	0.3	0.3	0.3	0.3	0.3	0.3	0.3	0.3	0.3	0.3	0.3	0.3	0.3	0.3	0.3	4.9
1	F	Q (9) 15 S	0.2	0.8	0.2	0.8	0.2	0.8	0.2	0.8	0.2	0.8	0.2	0.8	0.2	0.8	0.2	0.8	0.2	6.8
0	E	Q (9) 15 S	0.3	0.7	0.3	0.7	0.3	0.7	0.3	0.7	0.3	0.7	0.3	0.7	0.3	0.7	0.3	0.7	0.3	6.7
1	E	Q (9) 15 S	0.6	0.6	0.6	0.6	0.6	0.6	0.6	0.6	0.6	0.6	0.6	0.6	0.6	0.6	0.6	0.6	0.6	4.8

SWITCH	FLASH CODE	ON	OFF	ON	OFF	ON	OFF	ON	OFF
A	B								
MORSE CODE ( ) INDICATES LETTER									
7	8	MO (A) 6 S	0.3	0.6	1.0	4.1			
7	B	MO (A) 8 S	0.4	0.6	2.0	5.0			
8	8	MO (A) 8 S	0.8	1.2	2.4	3.6			
B	8	MO (U) 10 S	0.3	0.7	0.3	0.7	0.9	7.1	
C	8	MO (U) 10 S	0.4	0.6	0.4	0.6	1.2	6.8	
D	8	MO (U) 10 S	0.5	0.5	0.5	0.5	1.5	6.5	
9	8	MO (A) 10 S	0.5	0.5	1.5	7.5			
8	9	MO (D) 10 S	5.0	1.0	1.0	1.0	1.0	1.0	
A	8	MO (A) 15 S	0.5	1.5	2.0	11.0			
F	8	MO (U) 15 S	0.6	0.3	0.6	0.3	1.4	11.8	
0	9	MO (U) 15 S	0.7	0.5	0.7	0.5	1.9	10.7	
1	9	MO (U) 15 S	0.7	0.7	0.7	0.7	2.1	10.1	
7	D	MO (B) 15 S	1.5	0.5	0.5	0.5	0.5	0.5	10.5



## Maintenance and Servicing

Designed to be virtually maintenance-free, the SL-125, SL-125-C, & SL-125-GPS require minimal attention, though the following maintenance and servicing information is provided to help ensure the life of your Sealite product.

1. **Cleaning Lens-** occasional cleaning of the light lens may be required. Using a cloth and warm soapy water, wipe off any foreign matter before rinsing the lens with fresh water.
2. **Cleaning Solar Panels-** occasional cleaning of the solar panels may be required. Using a cloth and warm soapy water, wipe off any foreign matter before rinsing the panels with fresh water (SL-125-C models only).
3. **Battery Check-** inspection of batteries should be performed every three years (minimum) to ensure that the charger, battery and ancillary electronics are functioning correctly. Using a voltage meter, check that the battery voltage is at least 12 volts under 100mA load, and ensure all terminals are clear of foreign matter (SL-125-C models only).

### Replacing the Battery

The SL-125-C lanterns have a sealed battery compartment, which provides the user with the ability to change the battery after years of operation.

1. Remove the bolt/lock securing the battery box lid, and open unit.
2. Inside the battery box is an internal battery container. To access the battery, remove the four screws and lid of this internal container.
3. Remove old battery from container and disconnect all connecting wires. Discard battery in a safe manner.
4. Connect the "Battery Negative (-)" wire to the negative terminal of the new battery, and the "Battery Positive (+)" wire to the positive terminal of the new battery.
5. Connect the "Battery Positive (+)" and "Battery Negative (-)" wires from the Solar Regulator to the battery.
6. Replace the internal battery container lid and screws making sure no wires are protruding.
7. Close the battery box lid and secure with bolt/lock. Light is now activated.
8. To test place dark cover (towel or jacket) on top of light to activate sensor, light will come on within one minute.

***Care must be taken to observe the polarity of each wire before they are connected. To ensure waterproofing of the unit, make sure that no wires are protruding and that there is an even seal.***

***Always discard old batteries in a safe manner.***



## Trouble Shooting

Problem	Remedy
Lantern will not activate.	<ul style="list-style-type: none"> <li>• Ensure lantern is in darkness.</li> <li>• Wait at least 60 seconds for the program to initialise in darkness.</li> <li>• Ensure switch setting is on a valid code (not unused flash code).</li> <li>• Ensure battery terminals are properly connected.</li> <li>• Ensure battery voltage is above 12volts.</li> </ul>
Timing codes will not change.	<ul style="list-style-type: none"> <li>• Turn rotary switches several times to ensure contacts are clear.</li> </ul>
Lantern will not operate for the entire night.	<ul style="list-style-type: none"> <li>• Expose lantern to direct sunlight and monitor operation for several days. Sealite products typically require 1.5 hours of direct sunlight per day to retain full autonomy. From a discharged state, the lantern may require several days of operational conditions to 'cycle' up to full autonomy.</li> <li>• Reducing the light output intensity or duty cycle (flash code) will reduce current draw on the battery.</li> <li>• Ensure solar module is clean and not covered by shading during the day.</li> </ul>

## Sealite LED Light Warranty V2.2

### Activating the Warranty

Upon purchase, the Sealite Pty Ltd warranty must be activated for recognition of future claims. To do this you need to register on-line. Please complete the Online Registration Form at:

[www.sealite.com](http://www.sealite.com)

***Sealite Pty Ltd will repair or replace your LED light in the event of electronic failure for a period of up to three years from the date of purchase, as per the terms & conditions below.***

***Sealite Pty Ltd will repair or replace any ancillary or accessory products in the event of failure for a period of up to one year from the date of purchase, as per the terms & conditions below.***

***The unit(s) must be returned to Sealite freight prepaid.***

### Warranty Terms

1. Sealite Pty Ltd warrants that any Sealite marine products fitted with telemetry equipment including but not limited to AIS, GSM, GPS or RF ("Telemetry Products") will be free from defective materials and workmanship under normal and intended use, subject to the conditions hereinafter set forth, for a period of twelve (12) months from the date of purchase by the original purchaser.
2. Sealite Pty Ltd warrants that any BargeSafe™ Series of LED barge light products ("BargeSafe™ Products") will be free from defective materials and workmanship under normal and intended use, subject to the conditions hereinafter set forth, for a period of twelve (12) months from the date of purchase by the original purchaser.
3. Sealite Pty Ltd warrants that any LED area lighting products ("Area Lighting Products") but not including sign lighting products will be free from defective materials and workmanship under normal and intended use, subject to the conditions hereinafter set forth, for a period of twelve (12) months from the date of purchase by the original purchaser.
4. Sealite Pty Ltd warrants that any ancillary products and accessories, not mentioned in other clauses in this section, will be free from defective materials and workmanship under normal and intended use, subject to the conditions hereinafter set forth, for a period of twelve (12) months from the date of purchase by the original purchaser.
5. Sealite Pty Ltd warrants that any LED sign lighting products ("Sign Lighting Products") will be free from defective materials and workmanship under normal and intended use, subject to the conditions hereinafter set forth, for a period of three (3) years from the date of purchase by the original purchaser.
6. Sealite Pty Ltd warrants that any Sealite marine lighting products other than the Telemetry Products, BargeSafe™ Products, and Area Lighting Products ("Sealite Products") will be free from defective materials and workmanship under normal and intended use, subject to the conditions hereinafter set forth, for a period of three (3) years from the date of purchase by the original purchaser.
7. Sealite Pty Ltd will repair or replace, at Sealite's sole discretion, any Telemetry Products, BargeSafe™ Products, Area Lighting Products or Sealite Products found to be defective in material and workmanship in the relevant warranty period so long as the Warranty Conditions (set out below) are satisfied.
8. If any Telemetry Products, BargeSafe™ Products, Area Lighting Products or Sealite Products are fitted with a rechargeable battery, Sealite Pty Ltd warrants the battery will be free from defect for a period of one (1) year when used within original manufacturer's specifications and instructions.
9. Buoy products are covered by a separate 'Sealite Buoy Warranty'.

### Warranty Conditions

This Warranty is subject to the following conditions and limitations;

1. The warranty is applicable to lanterns manufactured from 1/1/2009.
2. The warranty is void and inapplicable if:
  - a. the product has been used or handled other than in accordance with the instructions in the owner's manual and any other information or instructions provided to the customer by Sealite;
  - b. the product has been deliberately abused, or misused, damaged by accident or neglect or in being transported; or
  - c. the defect is due to the product being repaired or tampered with by anyone other than Sealite or



- authorised Sealite repair personnel.
3. The customer must give Sealite Pty Ltd notice of any defect with the product within 30 days of the customer becoming aware of the defect.
  4. Rechargeable batteries have a limited number of charge cycles and may eventually need to be replaced. Typical battery replacement period is 3-4 years. Long term exposure to high temperatures will shorten the battery life. Batteries used or stored in a manner inconsistent with the manufacturer's specifications and instructions shall not be covered by this warranty.
  5. No modifications to the original specifications determined by Sealite shall be made without written approval of Sealite Pty Ltd.
  6. Sealite lights can be fitted with 3rd party power supplies and accessories but are covered by the 3rd party warranty terms and conditions.
  7. The product must be packed and returned to Sealite Pty Ltd by the customer at his or her sole expense. Sealite Pty Ltd will pay return freight of its choice. A returned product must be accompanied by a written description of the defect and a photocopy of the original purchase receipt. This receipt must clearly list model and serial number, the date of purchase, the name and address of the purchaser and authorised dealer and the price paid by the purchaser. On receipt of the product, Sealite Pty Ltd will assess the product and advise the customer as to whether the claimed defect is covered by this warranty.
  8. Sealite Pty Ltd reserves the right to modify the design of any product without obligation to purchasers of previously manufactured products and to change the prices or specifications of any product without notice or obligation to any person.
  9. Input voltage shall not exceed those recommended for the product.
  10. Warranty does not cover damage caused by the incorrect replacement of battery in solar lantern models.
  11. This warranty does not cover any damage or defect caused to any product as a result of water flooding or any other acts of nature.
  12. There are no representations or warranties of any kind by Sealite or any other person who is an agent, employee, or other representative or affiliate of Sealite, express or implied, with respect to condition of performance of any product, their merchantability, or fitness for a particular purpose, or with respect to any other matter relating to any products.

### **Limitation of Liability**

To the extent permitted by acts and regulations applicable in the country of manufacture, the liability of Sealite Pty Ltd under this Warranty will be, at the option of Sealite Pty Ltd, limited to either the replacement or repair of any defective product covered by this Warranty. Sealite will not be liable to Buyer for consequential damages resulting from any defect or deficiencies.

### **Limited to Original Purchaser**

This Warranty is for the sole benefit of the original purchaser of the covered product and shall not extend to any subsequent purchaser of the product.

### **Miscellaneous**

Apart from the specific warranties provided under this warranty, all other express or implied warranties relating to the above product is hereby excluded to the fullest extent allowable under law. The warranty does not extend to any lost profits, loss of good will or any indirect, incidental or consequential costs or damages or losses incurred by the purchaser as a result of any defect with the covered product.

### **Warrantor**

Sealite Pty Ltd has authorised distribution in many countries of the world. In each country, the authorised importing distributor has accepted the responsibility for warranty of products sold by distributor. Warranty service should normally be obtained from the importing distributor from whom you purchased your product. In the event of service required beyond the capability of the importer, Sealite Pty Ltd will fulfil the conditions of the warranty. Such product must be returned at the owner's expense to the Sealite Pty Ltd factory, together with a photocopy of the bill of sale for that product, a detailed description of the problem, and any information necessary for return shipment.

**Other Sealite Products Available**



**Marine Lanterns  
(1-19NM)**



**Monitoring  
& Control Systems**



**Bridge & Barge Lights**



**Marine Buoys  
(up to 3mt in diameter)**



**Area Lighting**



**Mooring Systems  
& Accessories**



**Sealite**  
www.sealite.com

AUSTRALIA  
t: +61 (0)3 5977 6128

USA  
t: +1 (603) 737 1311

UNITED KINGDOM  
t: +44 (0) 1502 588026

