

# INSTALLATION MANUAL

## ZX60 & ZX100 COMMERCIAL SOLAR LIGHTING SYSTEM



**IMPORTANT:** Always install the system assembly on the pole before inserting the batteries. The assembly system should never be manipulated when the batteries are installed inside.

### LIST OF MATERIAL

- A) Solar module with integrated control system and wiring. (1 per system)
- B) Battery main enclosure (1 per system)
- C) Battery, 12V (1 per system)
- D) Stainless Steel Hardware, 1/4"-20 (ZX60) or 5/16"-18 (ZX100) for system assembly
- E) LED Luminaire (12Vdc compatible only)
- F) Luminaire mounting tenon (hardware 5/16-18x1" included)

**Note :** The ZX system operates at 12Vdc. Other voltage will damage system.

**ZX SYSTEM COMPONENTS**

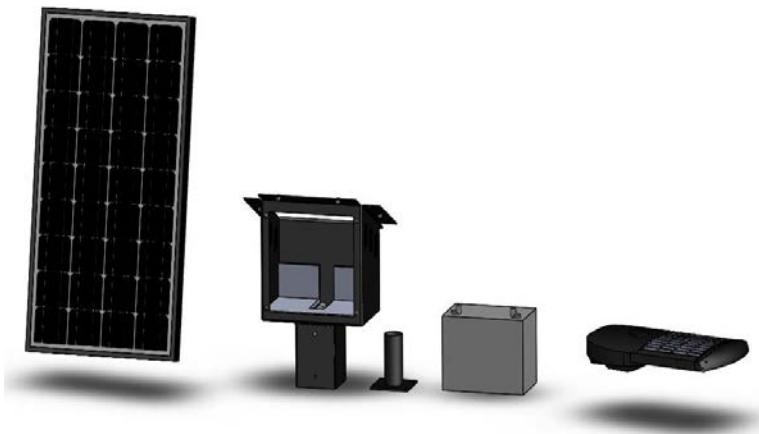

**ZX FINAL ASSEMBLY**



# INSTALLATION MANUAL

## ZX60 & ZX100 COMMERCIAL SOLAR LIGHTING SYSTEM



### STEP 1:

Using the supplied 1/4"-20 (ZX60) bolts or the 5/16"-18 (ZX100) bolts and hardware (hex bolt, lock washer, flat washer), fasten the battery compartment to the solar module as indicated on the image. Orientation of the battery box is critical, use the "Door on this Side" sticker to confirm orientation.

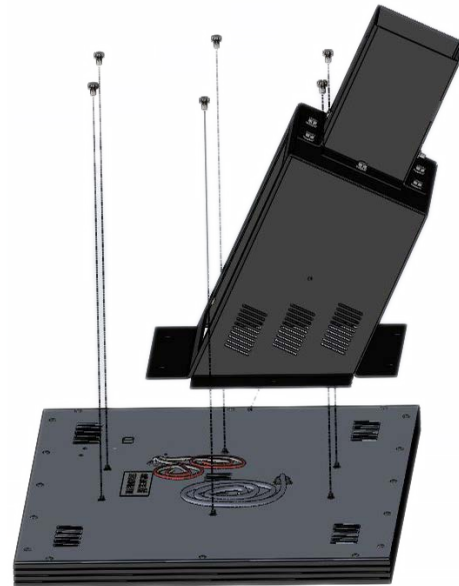
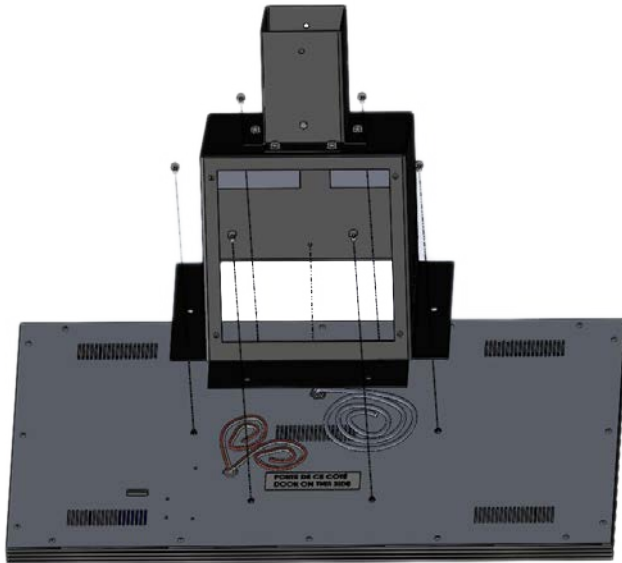

### Step 2: Find the optimal system orientation

- First determine the system orientation so that the solar module faces true south.
- Use the drill guide at the end of the document to drill the pole at the appropriate locations.
- Install the system on the pole. Use the 1/4"-20 bolt and hardware (bolts, flat washer, lock washer and nut) through the pole to secure in place.



# INSTALLATION MANUAL

## ZX60 & ZX100 COMMERCIAL SOLAR LIGHTING SYSTEM



### STEP 3:

Insert the luminaire power cable located in the battery main enclosure through the 90 deg connector located at the bottom to make it available for the luminaire connection. Supplied cable: #16 AWG, 6ft cable length, pre-installed on the control side.

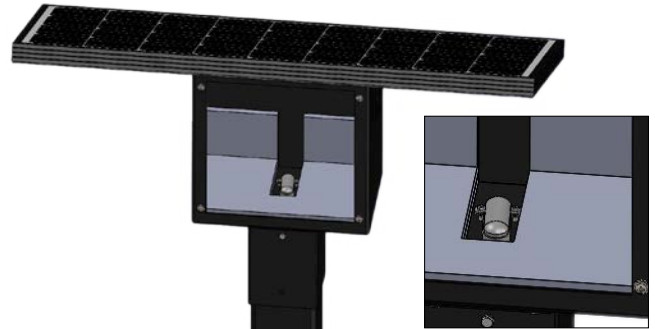

### Step 4:

Insert the battery inside the compartment and make the connection using the quick connector labeled "BATTERY".

Confirm proper system operation by **observing a green indicator light** behind the system status window.

**Important note: Never wire the "External PV" cable directly on the battery, this will cause irreversible damage to the battery. The "External PV" cable is used to add a solar module as needed.**



### STEP 5:

Close the quick access door.

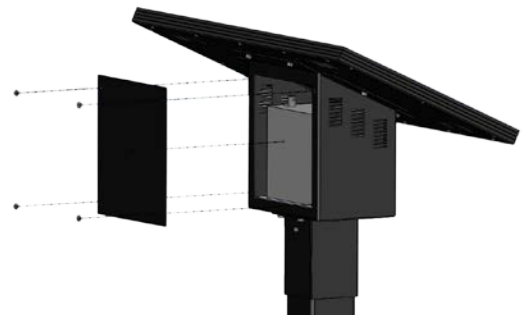

### STEP 6:

Install the tenon and light at the desired location. Refer to the tenon drawing and luminaire installation guide herein for more details.

**Avoid having the luminaire illuminate the solar module surface. This would cause synchronization errors as the artificial lighting coming from the luminaire would simulate daylight causing the luminaire to turn ON and OFF every 5 minutes.**

**The 12Vdc luminaire requires 3 connections:** Red positive (+), Black negative (-) and White dimming (signal). It is important to make all 3 connections so that the system operates correctly according to current or future operating profiles.

### 1.1 INSTALLATION GUIDELINES

To avoid a loss of autonomy and a malfunction:

- The luminaire must be installed horizontally and must never be tilted;
- The luminaire must be installed in an open space with no trees or structures nearby, this could favour snow accumulation and shading;
- The solar module must ideally oriented towards the south, otherwise see table “ORIENTATION AND AUTONOMY”.

Failing to follow these recommendations can result in loss of system performance.

#### FACTORS AFFECTING AUTONOMY:

Lack of sunshine, very low ambient temperature, snow accumulation due to trees or structures nearby, shading due to nearby trees or structures, solar module orientation (see table), sunshine below the monthly averages.

**SOLAR PANNEL ORIENTATION AND AUTONOMY**

Solar Module Orientation	Period	Autonomy losses
South (≈ optimal)	Annual	0%
	Summer	0%
	Winter	0%
East / West	Annual	-21%
	Summer	-15%
	Winter	-40%
North	Annual	-50%
	Summer	-41%
	Winter	-72%

### 1.2 STORAGE AND HANDLING:

If you wish to store the luminaire, the battery needs to be recharged before storing for a period of 15 days or more in order to prevent damage to the battery. The luminaire must be stored at 20°C room temperature.

**The luminaire should never be manipulated when the battery is inside. Use the quick access door to remove the battery before handling.**

### 1.3 DEEP DISCHARGE PROTECTION

This protection significantly increases battery lifespan. This protection also prevents permanent damage to the battery caused by very deep discharges during cold weather. **When the battery reaches a 50% state of charge, the battery is automatically disconnected from the system until it's state of charge reaches 85% i.e. about 1 day of sunshine in summer and about 4 days of sunshine in winter.**

### 1.4 DAY-NIGHT TRANSITION

The fixture uses the solar panel to detect day and night periods. The night transition requires a very low brightness level for 5 continuous minutes. This constraint prevents false night transitions. Avoid exposing the luminaire to an artificial light source that may cause synchronization errors by simulating the day. If the fixture operates erratically, make sure the solar module is not covered with debris or heavy snow. The luminaire automatically corrects synchronization errors after 24 hours. The occupancy sensor has its own photocell, which does not activate when the ambient brightness is too high.

1

2

B

B

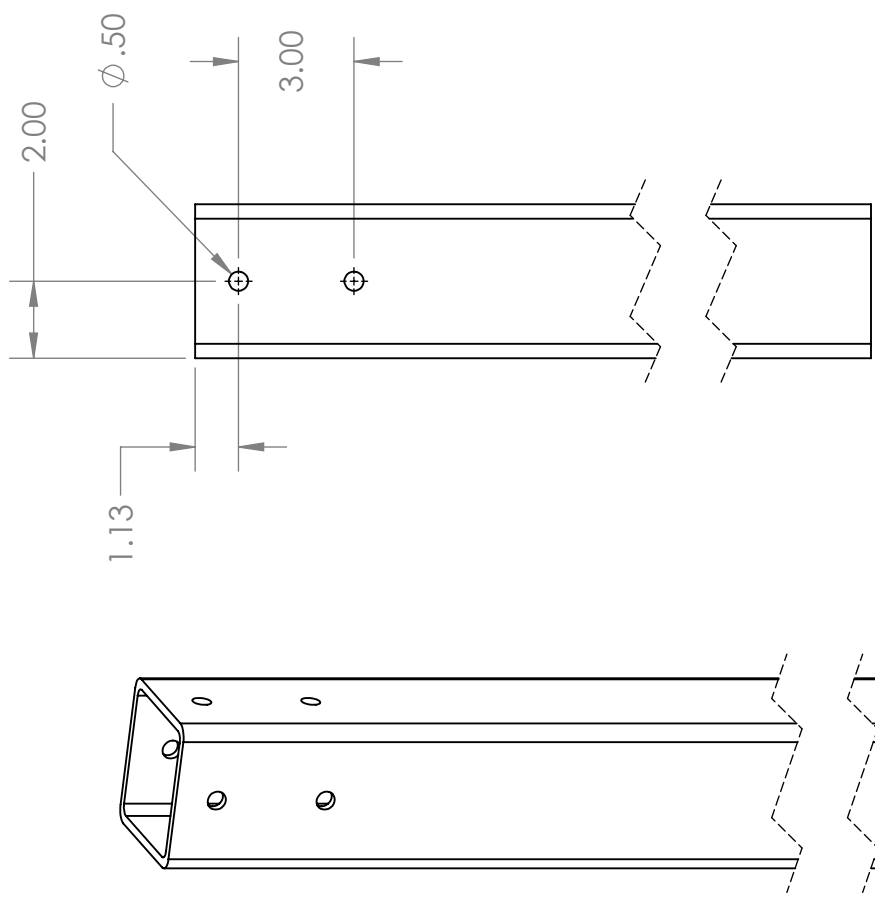

**NOTE:**

The installation of the battery box on the top of the lamp post requires drilling the post as per the presented drilling pattern. The lamp will be secured using one bolt going through the lamp post.

Drill on the 4 faces to facilitate the installation.

**POLE NOT INCLUDED**  
**Tenon drilling pattern not shown here.**

A

A

UNLESS OTHERWISE SPECIFIED: DIMENSIONS ARE IN INCHES		DRAWN	NAME	DATE	PROJECT:
DEFAULT TOLERANCES: ANGULAR ±1° TWO PLACE DECIMAL ±.06" THREE PLACE DECIMAL ±.031" HOLES ±.005"		JFOL	JFOL	5 Jan 2021	ZX60
MATERIAL		<b>PROPRIETARY AND CONFIDENTIAL</b> THE INFORMATION CONTAINED IN THIS DRAWING IS THE SOLE PROPERTY OF VISION SOLAIRE INC ANY REPRODUCTION IN PART OR AS A WHOLE WITHOUT THE WRITTEN PERMISSION OF VISION SOLAIRE.COM IS PROHIBITED.			TITLE:
THICKNESS					4IN POST DRILLING PATTERN
FINISH		DO NOT SCALE DRAWING			SIZE DWG. NO. REV
					A ZX60-02 0
					SCALE: 1:5 WEIGHT: SHEET 1 OF 1

1

2

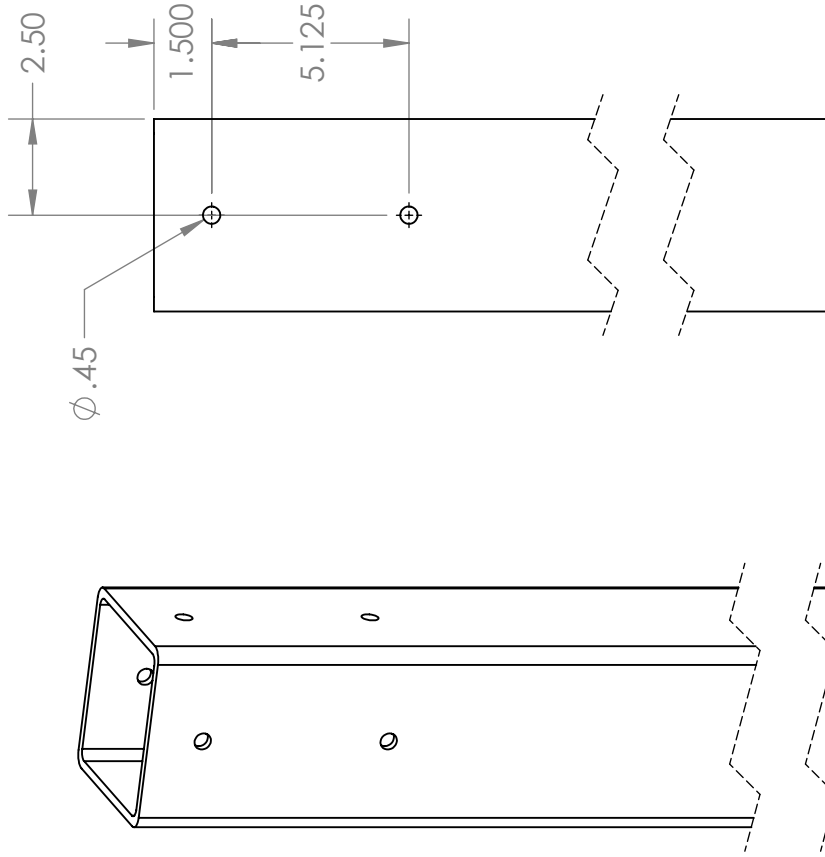

**NOTE:**

The installation of the battery box on the top of the lamp post requires drilling the post as per the presented drilling pattern. The lamp will be secured using one bolt going through the lamp post.

Drill on the 4 faces to facilitate the installation.

**POLE NOT INCLUDED**  
**Tenon drilling pattern not shown here.**

UNLESS OTHERWISE SPECIFIED: DIMENSIONS ARE IN INCHES		DRAWN	NAME	DATE	PROJECT:
DEFAULT TOLERANCES: ANGULAR $\pm 1^\circ$ TWO PLACE DECIMAL $\pm .06"$ THREE PLACE DECIMAL $\pm .031"$ HOLES $\pm .005"$		JFOL	JFOL	30 sep 2020	ZX100
MATERIAL Material <not specified>		<b>PROPRIETARY AND CONFIDENTIAL</b> THE INFORMATION CONTAINED IN THIS DRAWING IS THE SOLE PROPERTY OF VISION SOLAIRE INC ANY REPRODUCTION IN PART OR AS A WHOLE WITHOUT THE WRITTEN PERMISSION OF VISION SOLAIRE.COM IS PROHIBITED.			TITLE:
THICKNESS "					5IN POST DRILLING PATTERN
FINISH "		SIZE DWG. NO.			REV
DO NOT SCALE DRAWING		A ZX100-02			1
MODIFICATION OF THE NOTE		SCALE: 1:5			WEIGHT: 36.45
DESCRIPTION		SHEET 1 OF 1			

# LUMINAIRE TENON WHEN SQUARE POLE IS SELECTED. AVAILABLE FOR THE ZX60, ZX100 & ZX170.

Hardware 1/4-20x1" (4x) included for installing the tenon. Please coordinate drilling holes with your pole manufacturer.

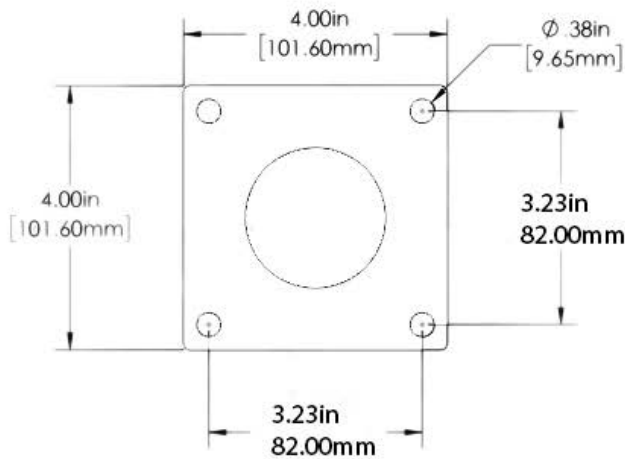
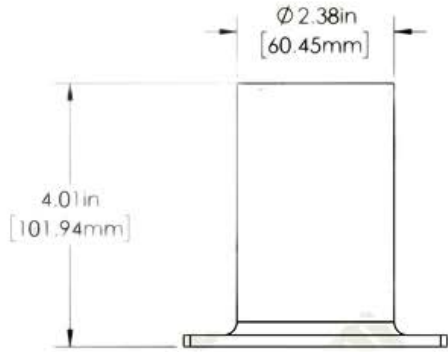

# LUMINAIRE TENON WHEN ROUND POLE IS SELECTED. AVAILABLE FOR THE ZX60 ONLY.

Hardware 5/16-18x1" (2x) included for installing the tenon. Please coordinate drilling holes with your pole manufacturer.

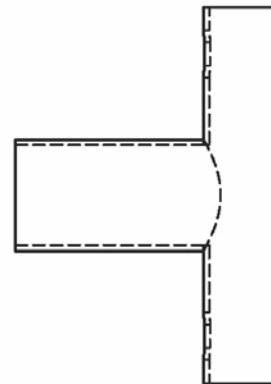
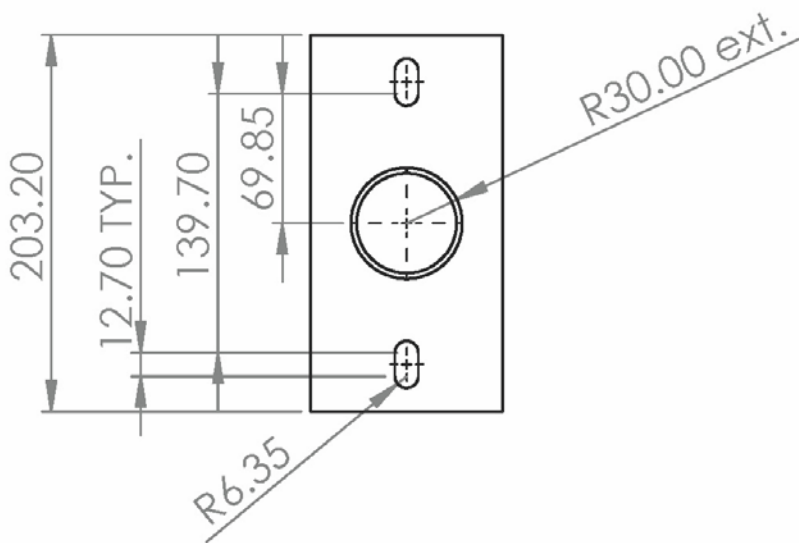
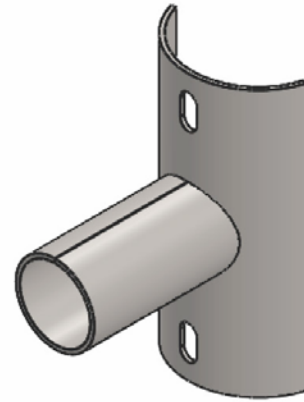
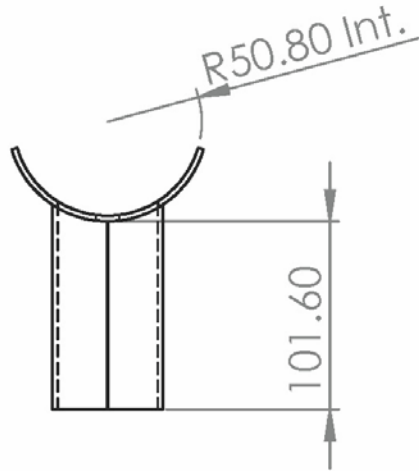



**IMPORTANT SAFEGUARDS**

When using electrical equipment, basic safety precautions should always be followed including the following:

**READ AND FOLLOW ALL SAFETY INSTRUCTIONS**

1. To avoid the possibility of electrical shock, turn off power supply before installation or servicing. Installation and servicing should be performed by qualified personnel.
2. When closing cover of fixture, be sure all wires are inside housing to avoid pinching wires.
3. If Photo Receptacle is installed refer to "Photo Control" section for instructions.
4. Product must be installed in accordance with your local electrical code. If you are not familiar with these codes and requirements, consult a qualified electrician.
5. Do not change the structure or any components of the fixture to ensure safety.

**SAVE THIS INSTRUCTIONS FOR FUTURE REFERENCE**

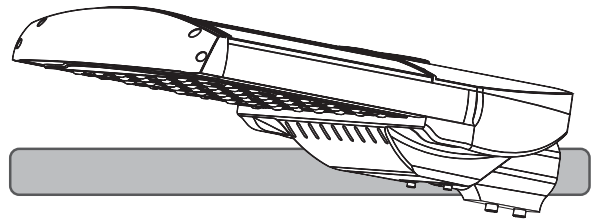

- \*Max installation height: 15M
- \*Pole fitter diameter:  $\Phi$  60mm (2.4") / \*48mm diameter need longer screws
- \*This product must be grounding

**TO INSTALL:**

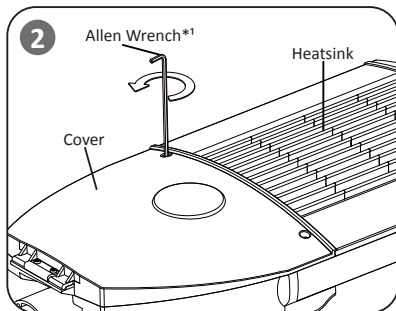
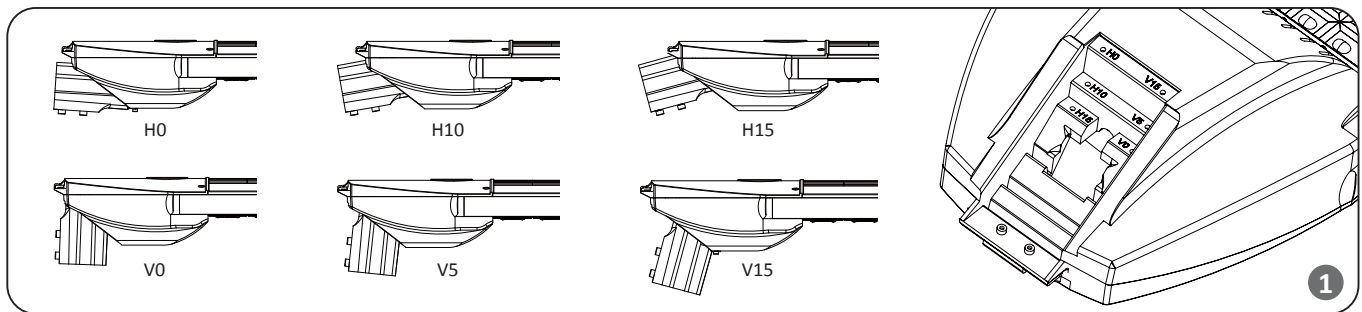

- \*1 Allen Wrench: 4mm (5/32")
- \*1 Inner Hexagon Screw: M5 (3/16")

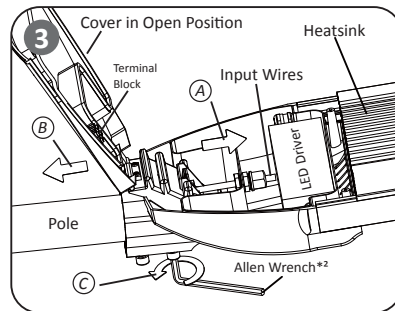

- \*2 Allen Wrench: 6mm (7/32")
- \*2 Inner Hexagon Screw: M8 (5/16")

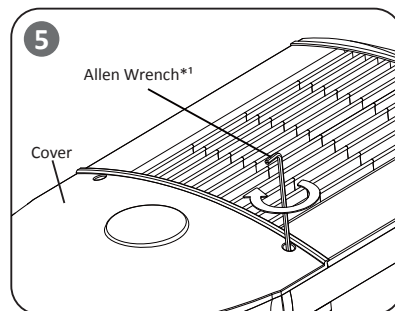
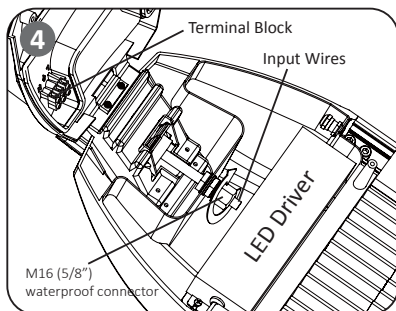

**STANDARD MOUNTING**

**STEP 1:** Adjust the multi-angle fitter (**0, 5, 15 degree vertical** and **0, 10, 15 degree horizontal**) to proper position by 4mm (5/32") allen wrench.

**STEP 2:** To open cover, hold fixture by heatsink with the light modules **facing down**. Remove 2 screws on the cover by 4mm (5/32") allen wrench.

**STEP 3:** Keep the cover in open position, lead the **Input Wires** in through the M16 (5/8") water-proof connector (**see A**). Do not tighten. Slide fixture onto pole (**see B**) and adjust to level position. Once desired position is achieved, tighten (2) mounting bolts (**see C**).

**STEP 4:** Connect the **Input Wires** into **Terminal Block**, Reference "**Electrical Connections**" section for completing electrical connections.

**STEP 5:** Close the cover, tighten (2) mounting bolts.

**IMPORTANT**  
DC(Direct Current) based system.

---

**STEP 1:**

Make the following Electrical Connections:

- a. Connect **INPUT POSITIVE(+)** conductor to **RED WIRE** position of the terminal block or POSITIVE(+) conductor of LED driver.
- b. Connect **INPUT NEGATIVE(-)** conductor to **BLACK WIRE** position of the terminal block or Vin NEGATIVE(-)/DIM (-) conductor of LED driver.
- c. Connect **INPUT DIM SIGNAL (WHITE WIRE)** to Dim (+) signal wire (blue) of LED Driver.

**STEP 2:**

Make sure all excess input wires are pushed into pole, screws are tightened.

**STEP 3:**

Close cover by firmly pushing cover towards fixture, making sure that no wires are pinched and Sealing gasket are fully engaged.

**STEP 4:**

If the fixture without a terminal block, please insulate all electrical connections with wire nuts suitable for at least 90°C

**DC BASED**

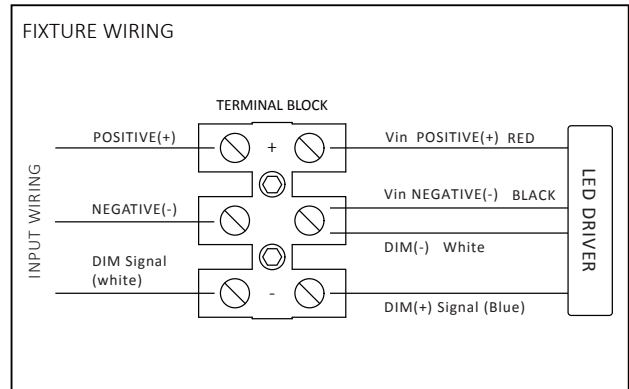

This marking indicates that this product should not be disposed with other household wastes throughout the EU. To prevent possible harm to the environment or human health from uncontrolled waste disposal, recycle it responsibly to promote the sustainable reuse of material resources. To return your used device, please use the return and collection systems or contact the retailer where the product was purchased. They can take this product for environmental safe recycling.